

Project:	Type:
Notes:	

UNA PRO 150 ADJUSTABLE X2 RECESSED DOUBLE (NON-IC)

Design Carlotta de Bevilacqua

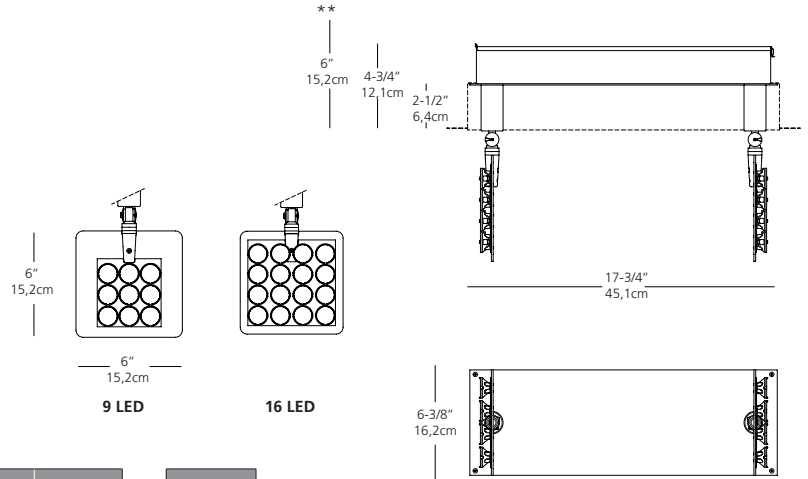

* Complete installation requires a mounting frame, sold separately (see page 2)
 ** 6" clearance requires for installation

#CAT	LED	HEAD	CCT	BEAM ANGLE	LENS HOLDER	DRIVER	FINISH	QUANTITY
USC-DPU		H2						

LED	S09 = 09 LED S16 = 16 LED
HEAD	H2 = Double
CCT	30 = 3000K, 80CRI
Beam angle	NB = Narrow beam 6° MB = Medium beam 20° WB = Wide beam 38°
Lens holder color	C = Clear
Driver	06 = DIM 2 wires (120V only) Phase dimming 08 = 0-10V dimming (UNV)
Finish	W = White/White (powder coat top plate and heatsink)

For different CCT, CRI or driver options,
 please contact your local Artemide Sales Representative

TECHNICAL DATA:

	80CRI / 3000k					
	9LED			16LED		
Beam angle:	6°	20°	38°	6°	20°	38°
Power consumption:	22W			42W		
Lumen Nominal:	1400lm			2540lm		
Lumen Delivered:	1072	1058	1034	1964	1858	1830
Efficacy lm/W :	48.7	48.1	47	46.8	44.2	43.6
Efficiency (%):	76%	76%	74%	77%	73%	72%

PHOTOMETRIC DATA:

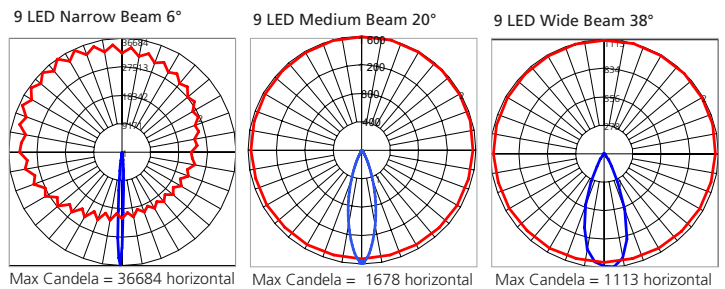

FEATURES:

- The led board is mounted on a rotating aluminum heatsink allowing a 360° orientation horizontally and 180° vertically.
- Lens holders are available in white and clear upon request.
- The galvanized steel driver housing is mounted on a flexible arm.
- Note: for other finishes, please contact your local Artemide sale representative.

- suitable for dry location

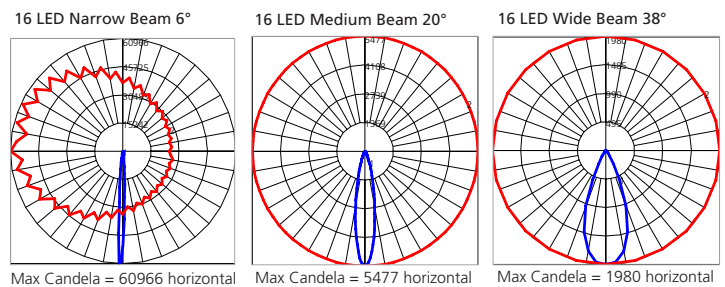

Project:	Type:
Notes:	

MOUNTING FRAME - UNA PRO 150 ADJUSTABLE X2 RECESSED DOUBLE (NON-IC)
Design Carlotta de Bevilacqua

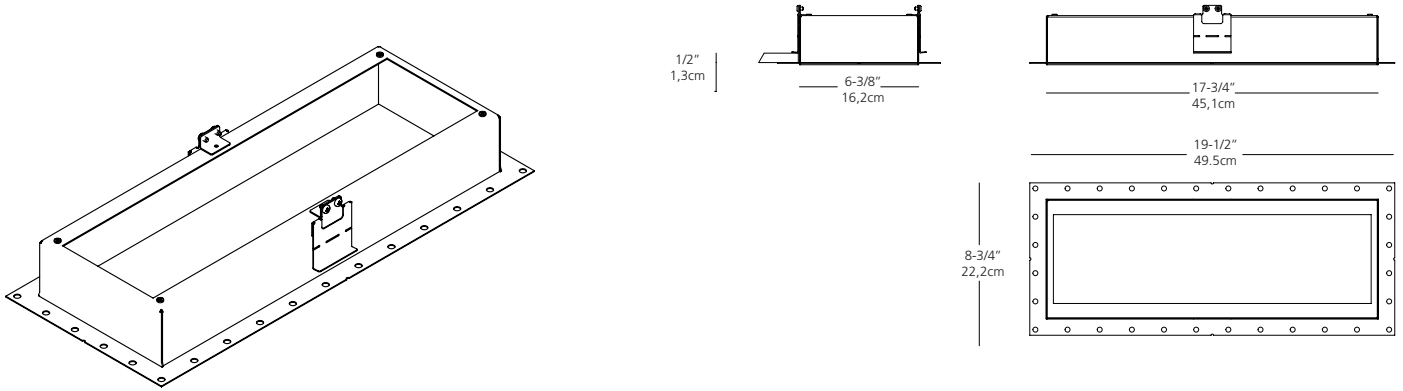

CEILING CUT-OUT:

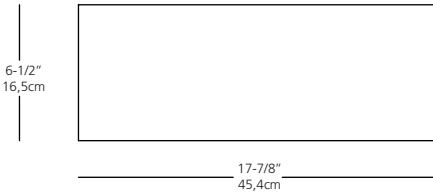

#CAT	FINISH	TEXTURE	QUANTITY
<input type="checkbox"/> USC-DPUSF2W	WHITE	FINE TEXTURE POWDER COAT	

FEATURES:

- Cold rolled steel housing with powder coat finish.
- Alignment details available on each sides of the frame for precise alignment.
- Ceiling mounting brackets hold the frame in place without the need of holding it for final adjustment.
- Ceiling brackets can accept ceiling thickness up to 1" (2,5cm).
- Note: for other finishes, please contact your local Artemide sale representative.

Project:	Type:
Notes:	

UNA PRO ACCESSORIES
Design Carlotta de Bevilacqua

Note : Lens kit and Lens Holder Kit are sold separately



Standard



Optional

Lens Holder Kit:

#CAT	type	kit	color	Quantity
USC-DPU	LH	___	___	___

Type	LH = Lens holder
Kit	4 = for 4 LED 16 = for 16 LED
Color	B = Black W = White C = Clear

Lens Kit:

#CAT	type	kit	color	Quantity
USC-DPU	L	___	___	___

Type	L = Lens
Kit	4 = for 4 LED 16 = for 16 LED
Color	NB = Narrow Beam 6° MB = Medium Beam 20° WB = Wide Beam 38°