

# Artemide®

## TURN AROUND SYSTEM SUSPENSION DIRECT EMISSION

design  
Carlotta de Bevilacqua

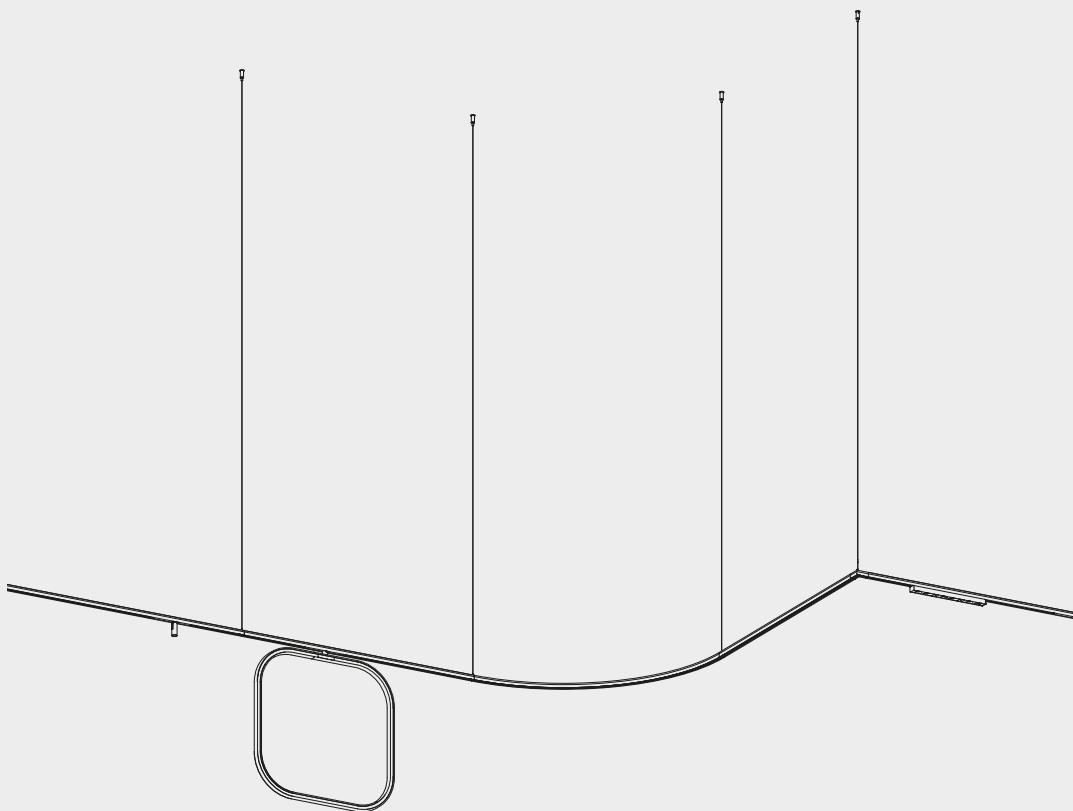



i

<p>NO DIM</p>				
		<b>Artemide App</b> Quick Starting Guide		

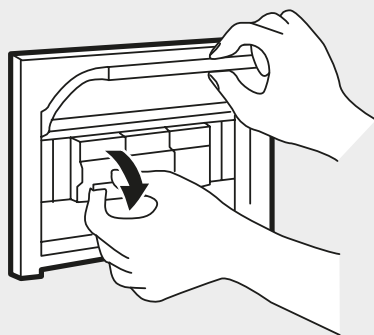
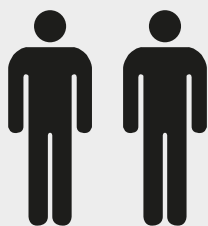



## EN IMPORTANT SAFETY INSTRUCTIONS.

**READ ALL OF THESE INSTALLATION INSTRUCTIONS BEFORE INSTALLING THE TRACK SYSTEM. SAVE THESE INSTRUCTIONS AND REFER TO THEM WHEN ADDING FIXTURES OR CHANGING THE TRACK CONFIGURATION.**

When installing or using this track system, basic safety precautions should always be followed, including the following:

1. Read all instructions.
2. Do not install this track in damp or wet locations.
3. Do not install any part of a track system less than 5 feet above the floor.
4. Do not install any fixtures closer than 6 inches from any curtain or similar combustible material.
5. Do not install the track with electric power connected. Similarly, disconnect electrical power when installing or removing fixtures or components or changing the configuration of the track.
6. Do not use this track with a power supply cord or convenience receptacle adapter.
7. Turn Around Track System is intended for use only with Turn Around Track System components and fixtures marked for use with Turn Around Track System. To reduce risk of fire and electric shock, do not use other components as part of this system.
8. Track installation is to only be performed by a certified electrician in accordance with the National Electrical Code and all local codes and ordinances.
9. Do not connect a track to more than one branch circuit unless the track is constructed so that it can be used with more than one branch circuit. Check with a qualified electrician. Although the track lighting system may seem to operate acceptably, a dangerous overload of the neutral may occur and result in a risk of fire.
10. Do not attempt to energize anything other than Lighting Track Fixtures on the track. To reduce the risk of fire and electrical shock, do not attempt to connect power tools, extension cords, appliances and the like to the track.

## FR INSTRUCTIONS DE SÉCURITÉ IMPORTANTES.

**LISEZ TOUTES CES INSTRUCTIONS D'INSTALLATION AVANT D'INSTALLER LE SYSTÈME DE RAILS. CONSERVEZ CES INSTRUCTIONS ET CONSULTEZ-LES LORSQUE VOUS AJOUTEZ DES APPAREILS OU MODIFIEZ LA CONFIGURATION DU SYSTÈME DE RAILS.**

Lors de l'installation ou de l'utilisation de ce système de rails, des précautions de sécurité de base doivent toujours être respectées, notamment les suivantes:

1. Lisez toutes les instructions.
2. N'installez pas ce rail dans des endroits humides ou mouillés.
3. N'installez aucune partie du système de rails à moins de 1,5 m du sol.
4. N'installez aucun appareil à moins de 6 pouces d'un rideau ou d'un matériau combustible similaire.
5. N'installez pas le rail lorsque le courant électrique est branché. De même, débranchez l'alimentation électrique lorsque vous installez ou retirez des appareils ou des composants ou lorsque vous modifiez la configuration du rail.
6. N'utilisez pas ce rail avec un cordon d'alimentation ou un adaptateur de prise de courant.
7. Le système Turn Around Track est conçu pour être utilisé uniquement avec les composants et les luminaires Turn Around Track System marqués pour une utilisation avec Turn Around Track System. Pour réduire les risques d'incendie et d'électrocution, n'utilisez pas d'autres composants dans ce système.
8. L'installation du rail ne doit être effectuée que par un électricien certifié, conformément au Code national de l'électricité et à tous les codes et ordonnances locaux.
9. Ne connectez pas un rail à plus d'un circuit de dérivation, sauf si le rail est construit de manière à pouvoir être utilisé avec plus d'un circuit de dérivation. Vérifiez auprès d'un électricien qualifié. Bien que le système d'éclairage sur rail puisse sembler fonctionner de manière acceptable, une surcharge dangereuse du neutre peut se produire et entraîner un risque d'incendie.
10. N'essayez pas de mettre sous tension autre chose que les appareils d'éclairage sur rail. Afin de réduire les risques d'incendie et d'électrocution, n'essayez pas de brancher des outils électriques, des rallonges, des appareils électroménagers ou autres sur le rail.

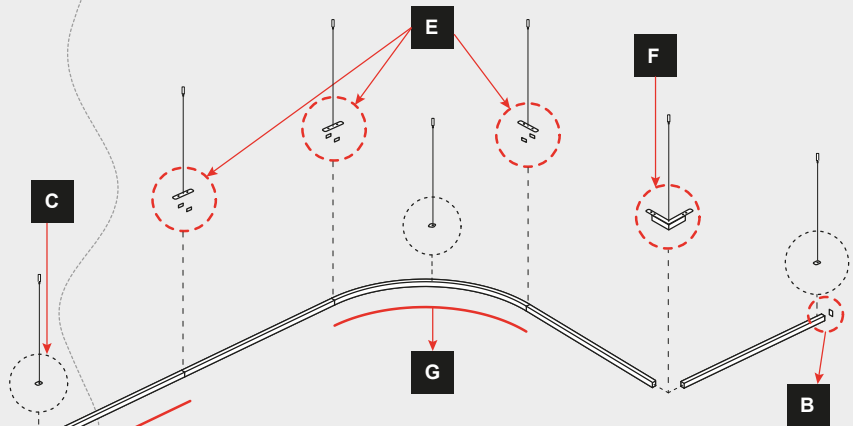
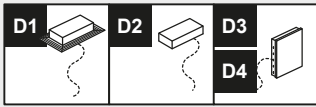
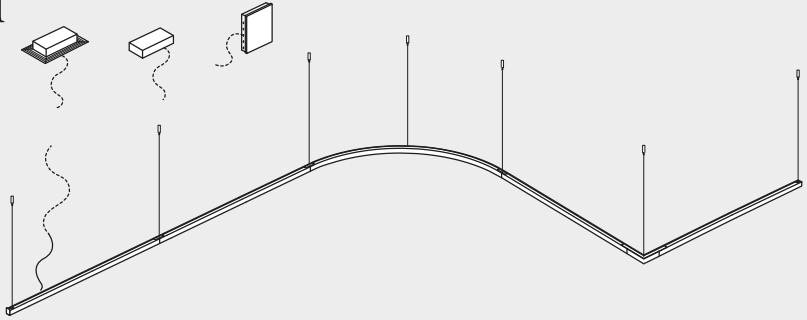
**i**

<b>A</b>	<b>Fig. 1</b>	<b>D1</b>	<b>Fig. 27</b>
<b>F</b>	<b>Fig. 21</b>	<b>D2</b>	<b>Fig. 45</b>
<b>G</b>	<b>Fig. 26</b>	<b>D3</b>	<b>Fig. 60</b>
		<b>D4</b>	<b>Fig. 72</b>

**A** [ 1000mm - 3.2 ft /  
L = 2000mm - 6.5 ft /  
3000mm - 9.8 ft

**G** [ 300mm - 11 <sup>13</sup>/<sub>16</sub>"  
90° R = 500mm - 19 <sup>11</sup>/<sub>16</sub>"  
700mm - 27 <sup>9</sup>/<sub>16</sub>"

300mm - 11 <sup>13</sup>/<sub>16</sub>"  
60° R = 500mm - 19 <sup>11</sup>/<sub>16</sub>"  
700mm - 27 <sup>9</sup>/<sub>16</sub>"

300mm - 11 <sup>13</sup>/<sub>16</sub>"  
45° R = 500mm - 19 <sup>11</sup>/<sub>16</sub>"  
700mm - 27 <sup>9</sup>/<sub>16</sub>"





A

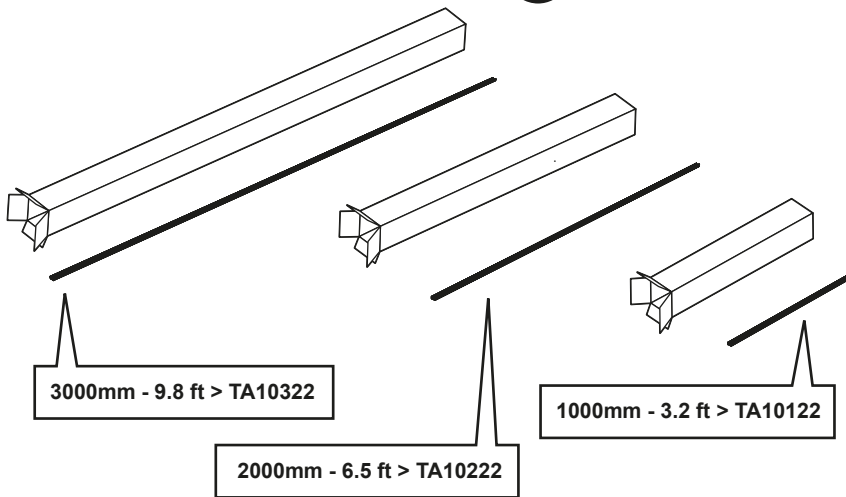
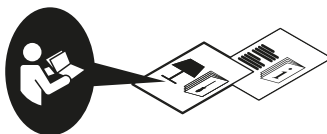

B

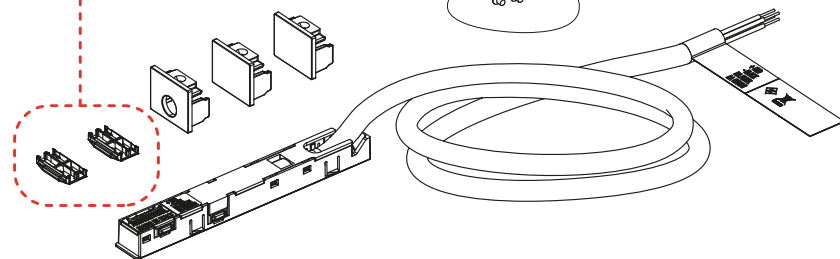
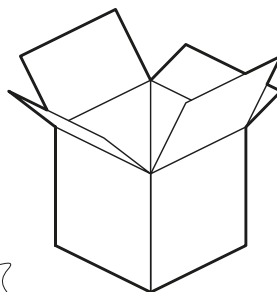
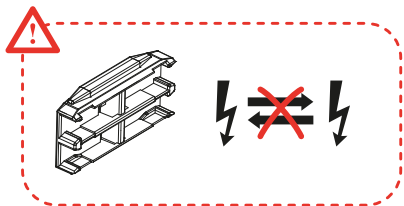
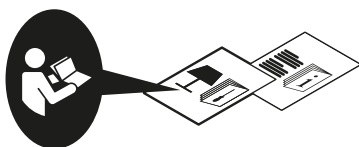



C

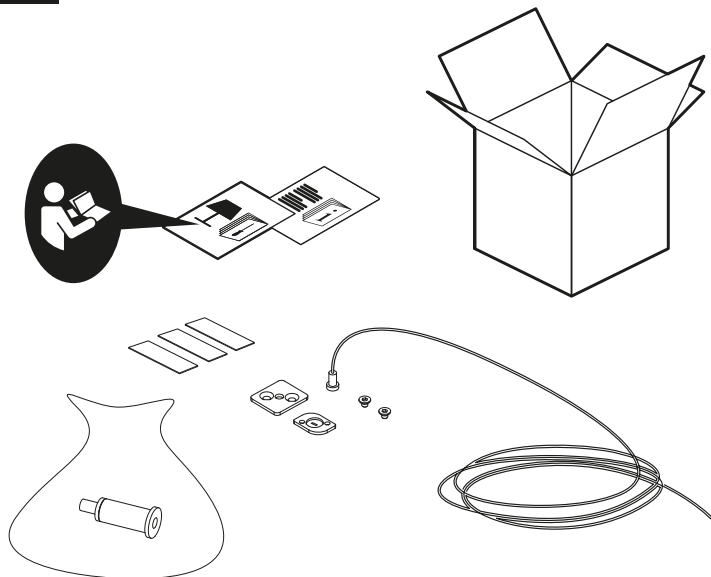

D1

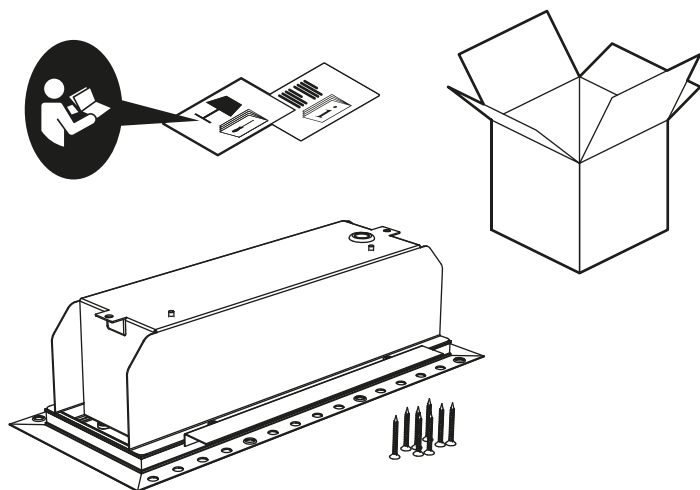



D2

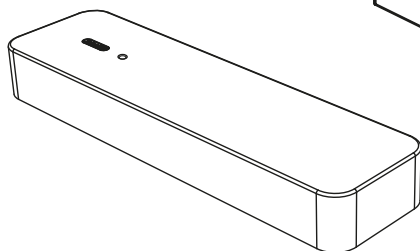
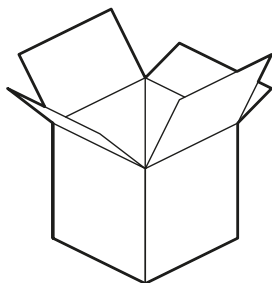
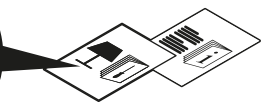

D3

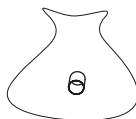
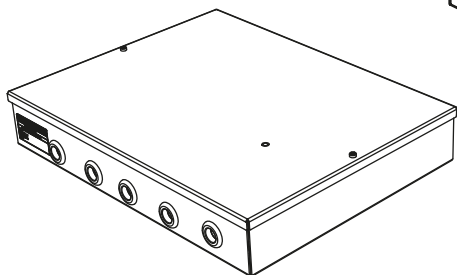
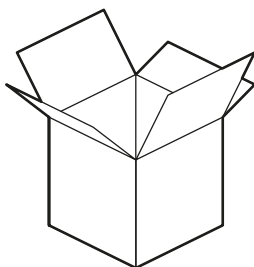
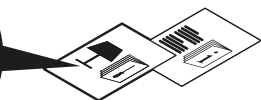



E

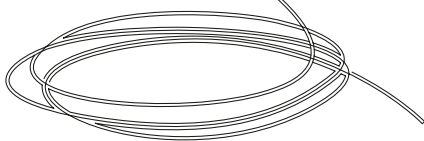
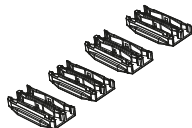
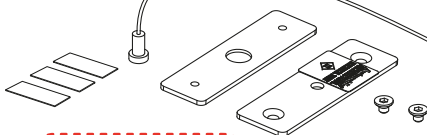
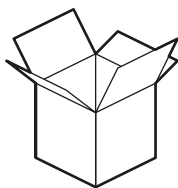
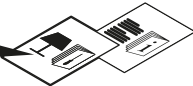
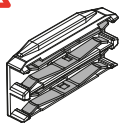

F

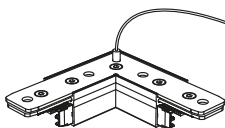
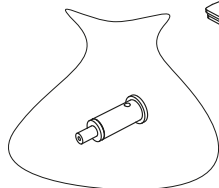
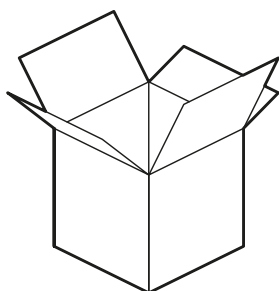
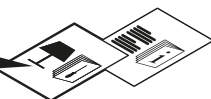

**G**

60° - R 300mm - 11 <sup>13</sup>/<sub>16</sub>" > TA40322  
 60° - R 500mm - 19 <sup>11</sup>/<sub>16</sub>" > TA40422  
 60° - R 700mm - 27 <sup>9</sup>/<sub>16</sub>" > TA40522



45° - R 300mm - 11 <sup>13</sup>/<sub>16</sub>" > TA40022  
 45° - R 500mm - 19 <sup>11</sup>/<sub>16</sub>" > TA40122  
 45° - R 700mm - 27 <sup>9</sup>/<sub>16</sub>" > TA40222

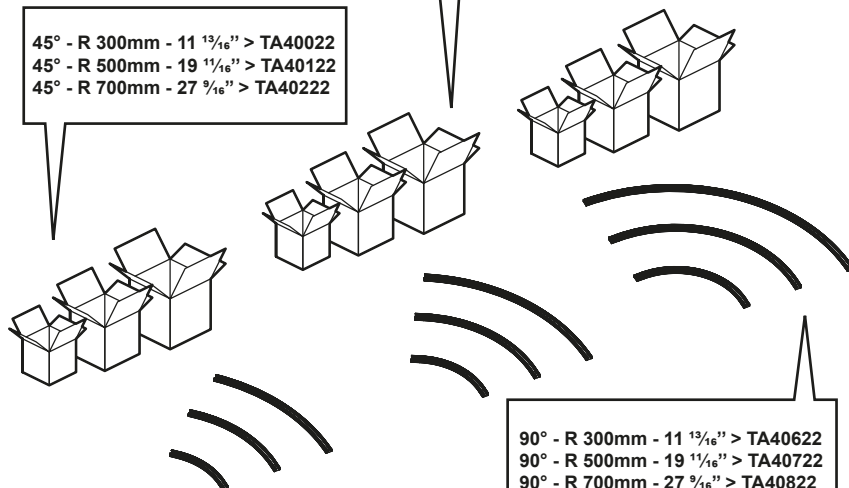

90° - R 300mm - 11 <sup>13</sup>/<sub>16</sub>" > TA40622  
 90° - R 500mm - 19 <sup>11</sup>/<sub>16</sub>" > TA40722  
 90° - R 700mm - 27 <sup>9</sup>/<sub>16</sub>" > TA40822

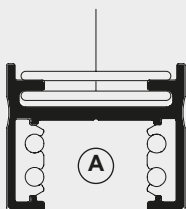
**i**

	<b>A</b>
VECTOR 20 TRACK	✓
VECTOR 30 TRACK	✓
VECTOR 40 TRACK	✓
VECTOR 20 PENDANT TRACK	✓
VECTOR 30 PENDANT TRACK	✓
SHARPING 8X LED	✓
SHARPING 12X LED	✓
STRIP LED	✓
SQUARE HORIZONTAL	✓
SQUARE HORIZONTAL TRACK	✗
SQUARE VERTICAL	✓

**i**

### REQUIRED HARDWARE QUINCAILLERIE REQUISE



#8 screws for wall mounting  
Vis pour montage mural #8



Wall anchors suitable for screw size  
Encrages appropriés à la taille de vis

**i**

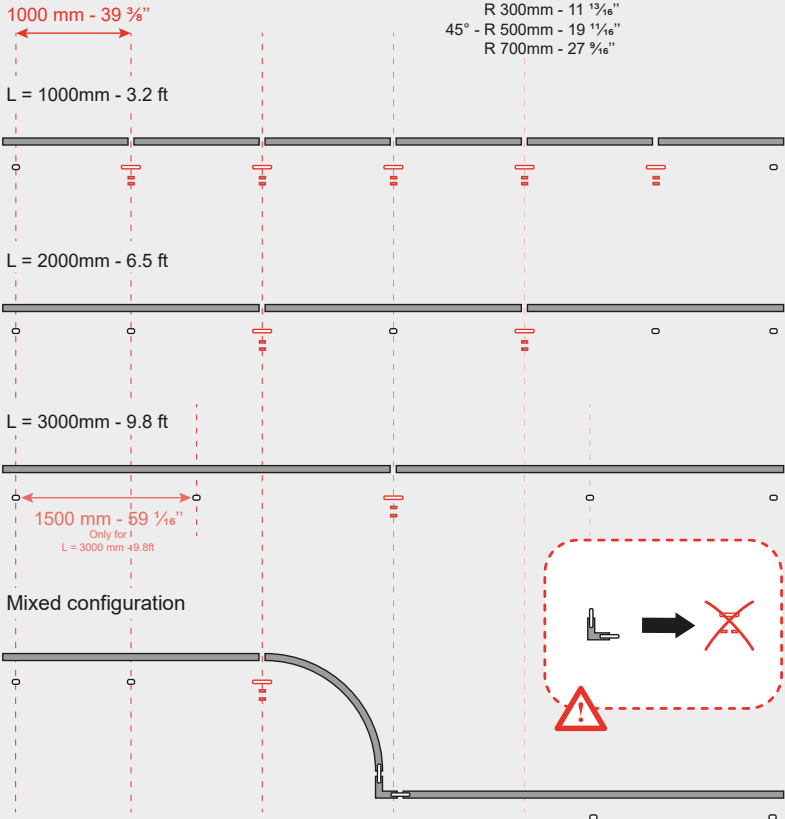
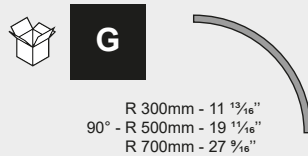
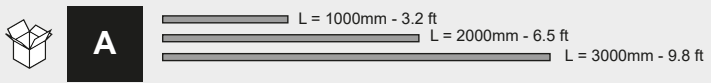

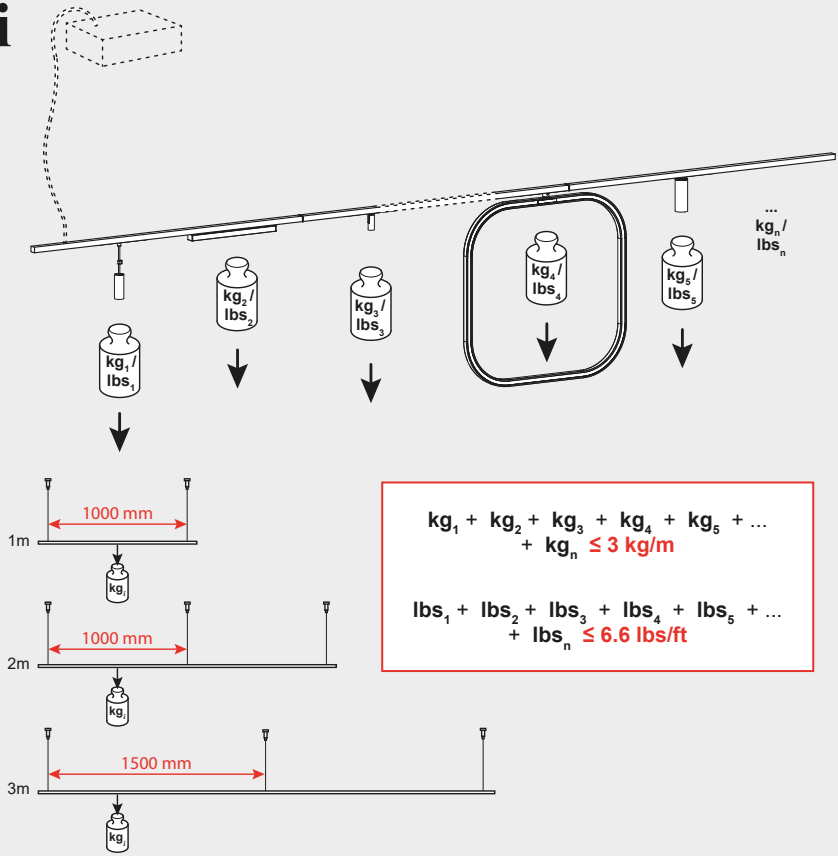
**i****i**

Output Max = Max admitted power [W]	Inrush current (typ @230VAC) [A]	$t_{width}$ measured at 50% I <sub>peak</sub> [msec]	Number of power unit under same MCB			
			B16A	B25A	C16A	C25A
270	70	1011	1	1	2	2
210	75	570	2	3	4	5
125	65	550	3	4	6	7

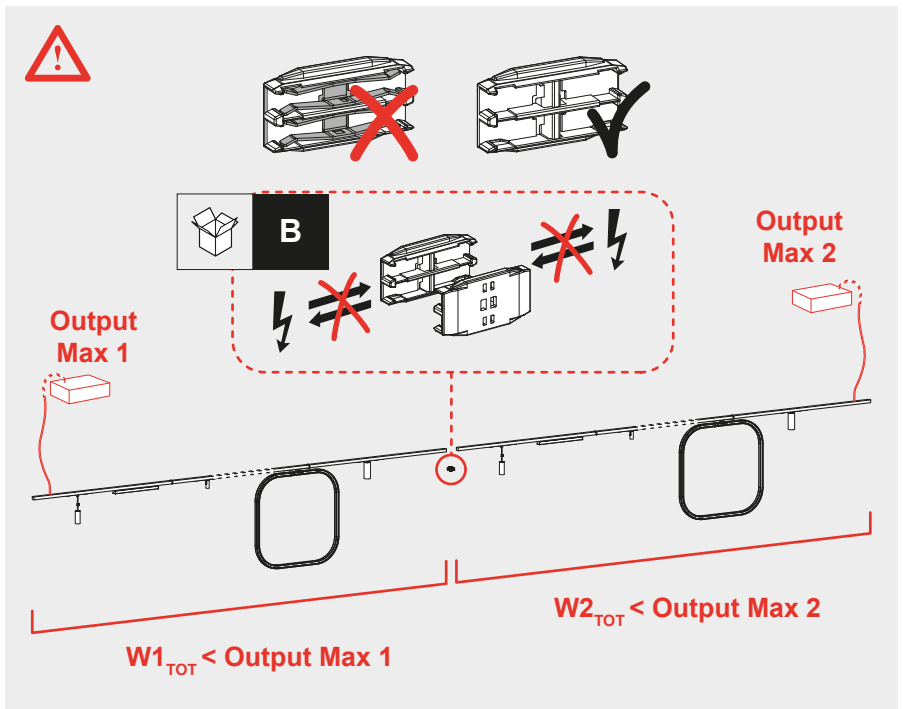
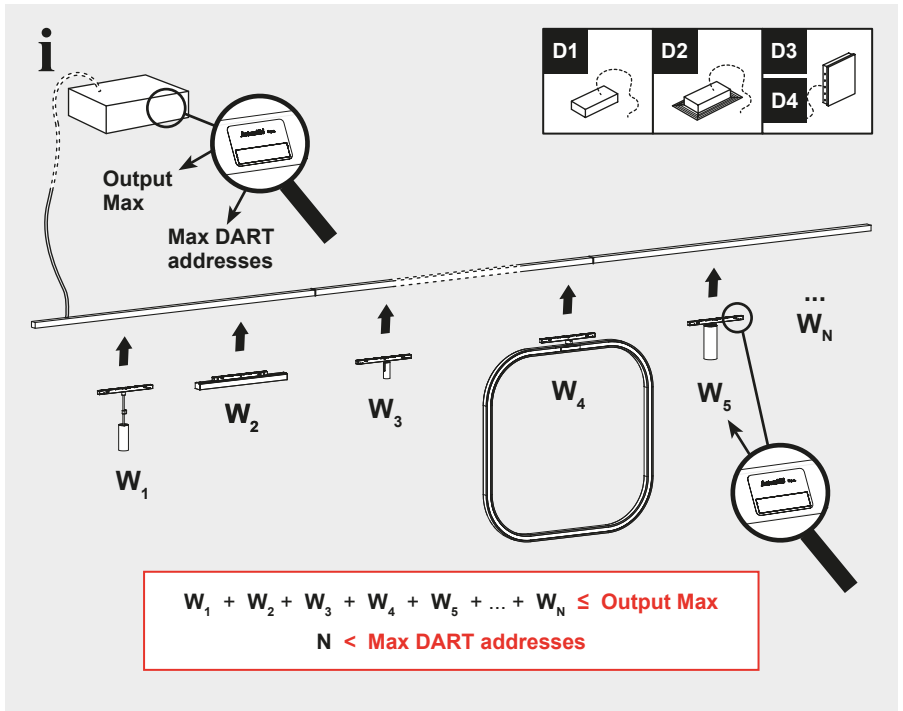



**i**

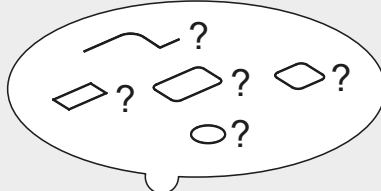
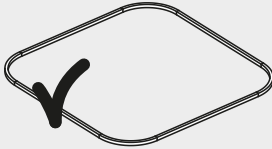
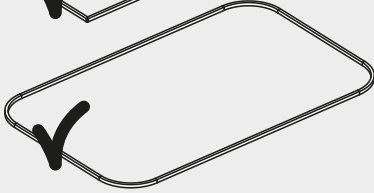
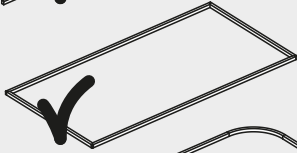

**i**

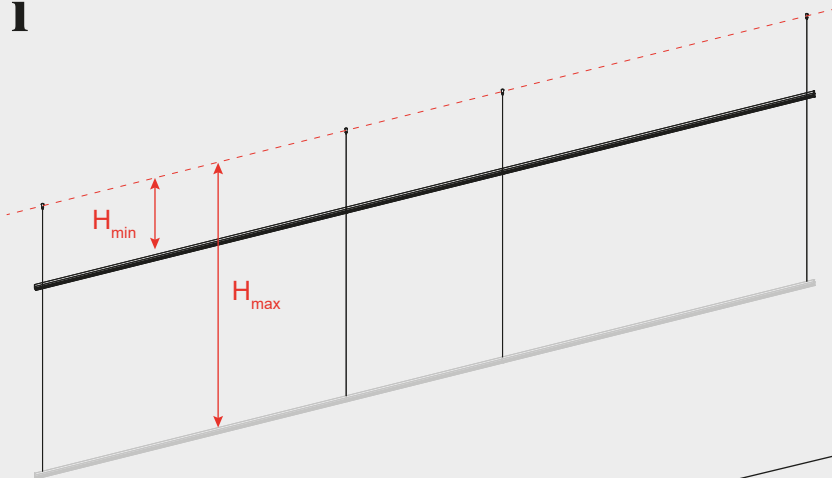

$H_{min}$  300 mm (1 ft) -  $H_{max}$  2000 mm (6.5 ft)

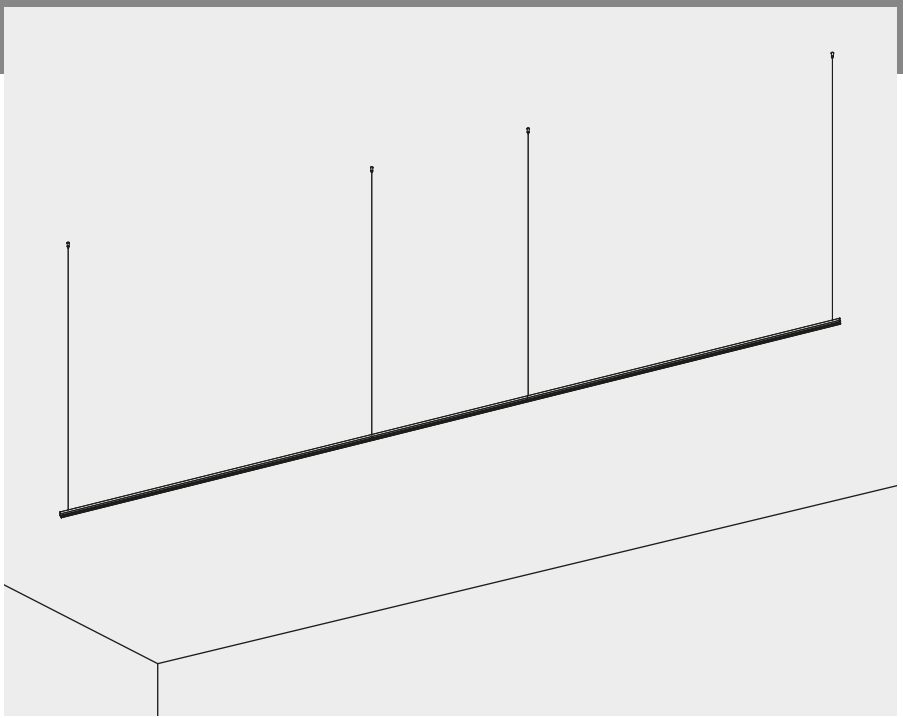

**i**

**L = 1000mm - 3.2 ft**

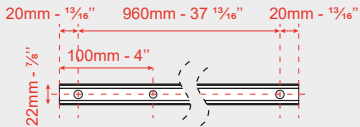

**L = 2000mm - 6.5 ft**

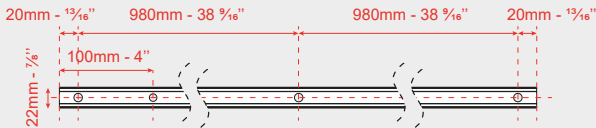

**L = 3000mm - 9.8 ft**

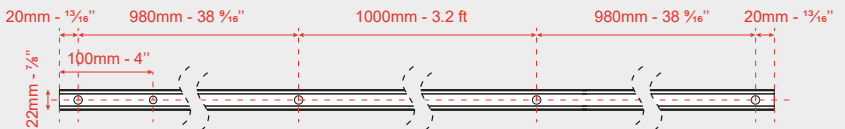

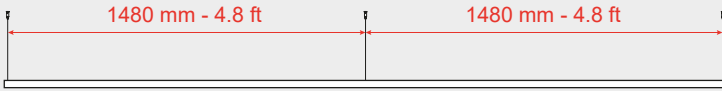
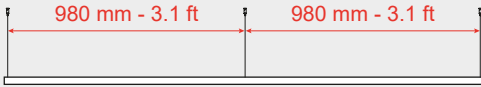
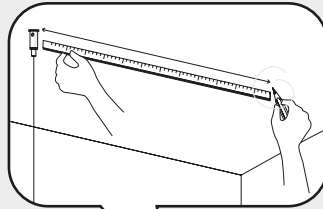
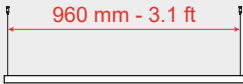
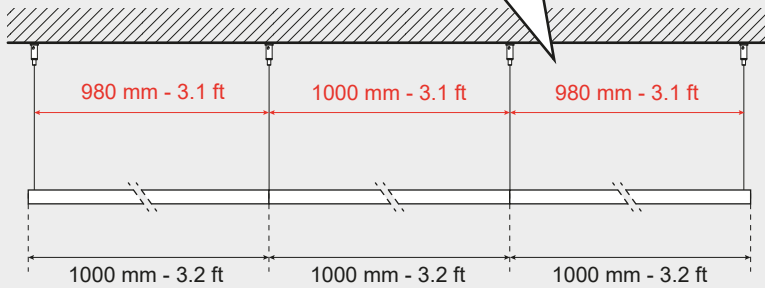
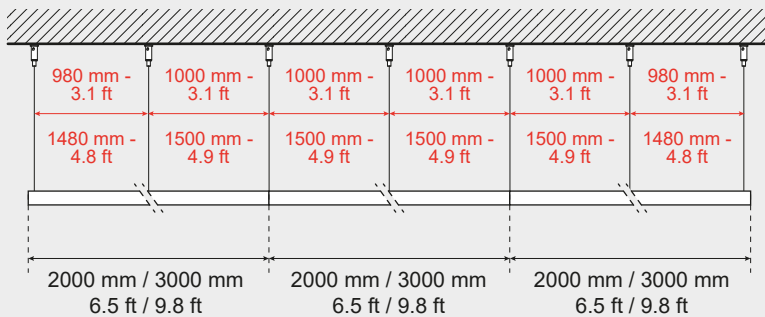
**i****L = 3000mm - 9.8 ft****L = 2000mm - 6.5 ft****L = 1000mm - 3.2 ft****L = 1000 mm - 3.2 ft****L = 2000 / 3000 mm - 6.5 ft / 9.8 ft**

1

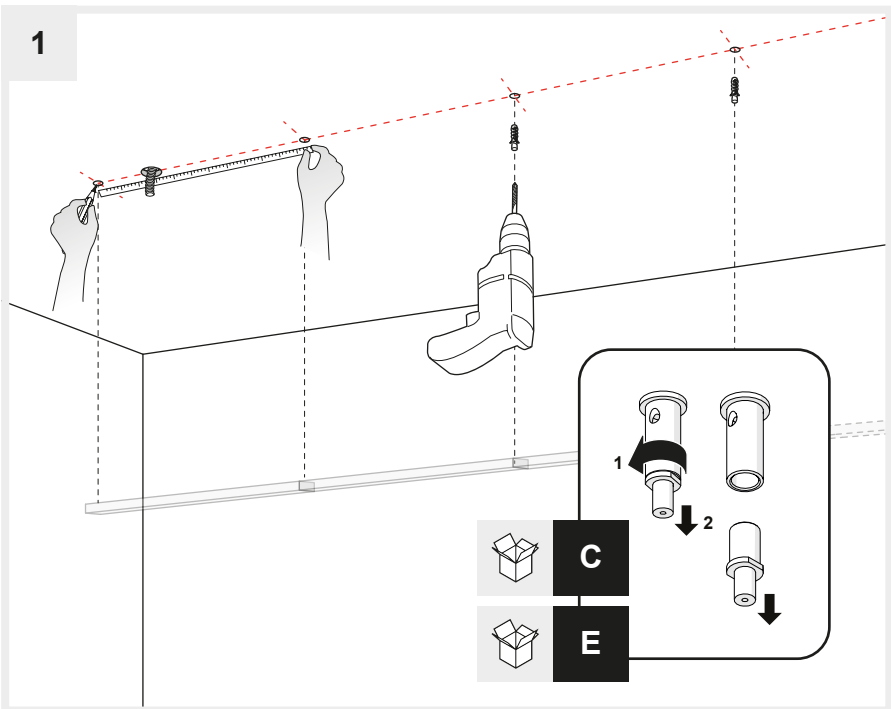

2

**i** REQUIRED HARDWARE  
QUINCAILLERIE REQUISE

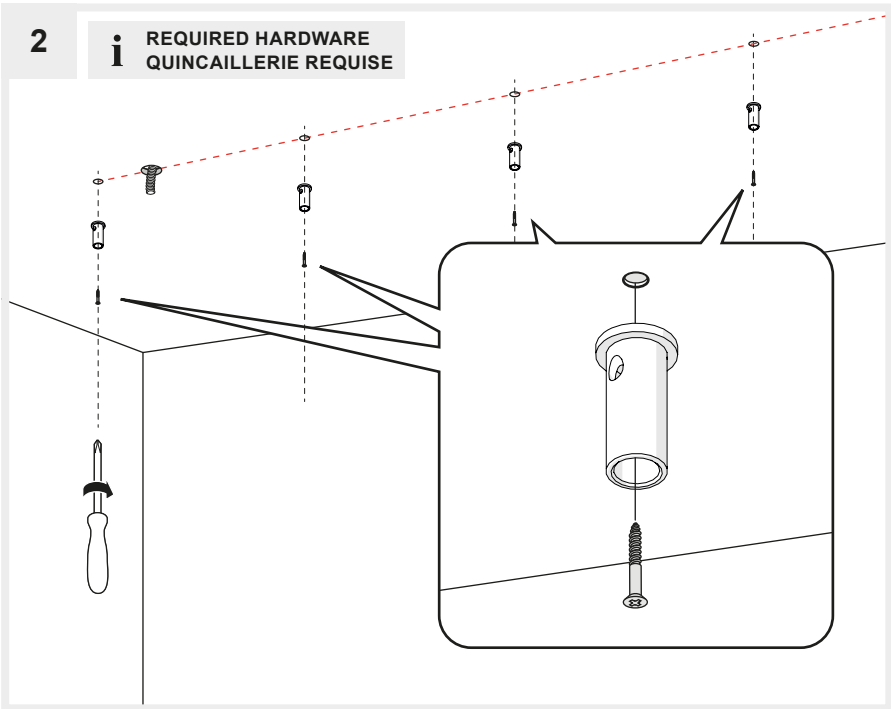

3

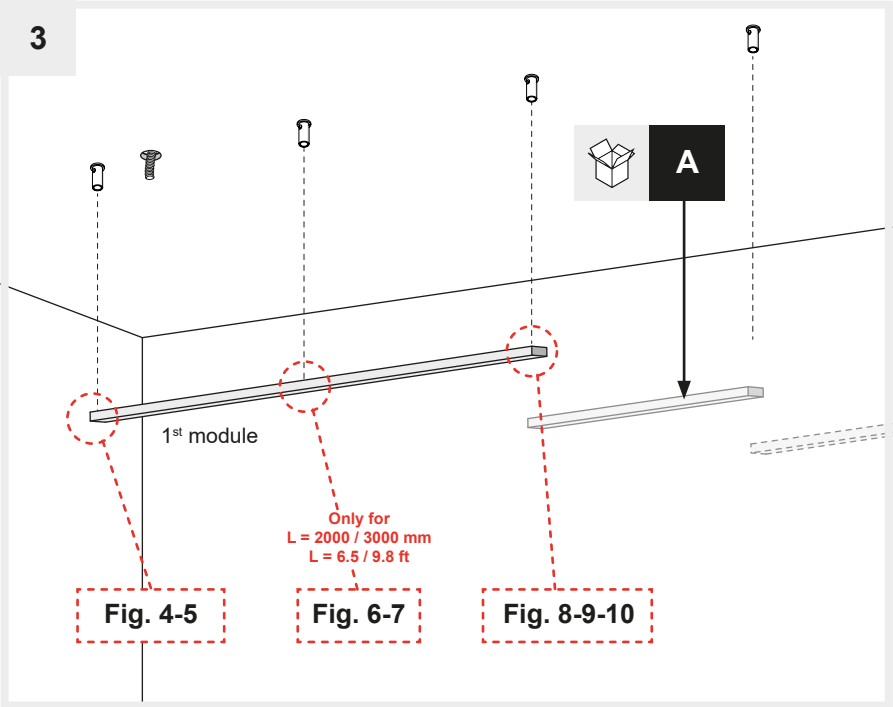

4

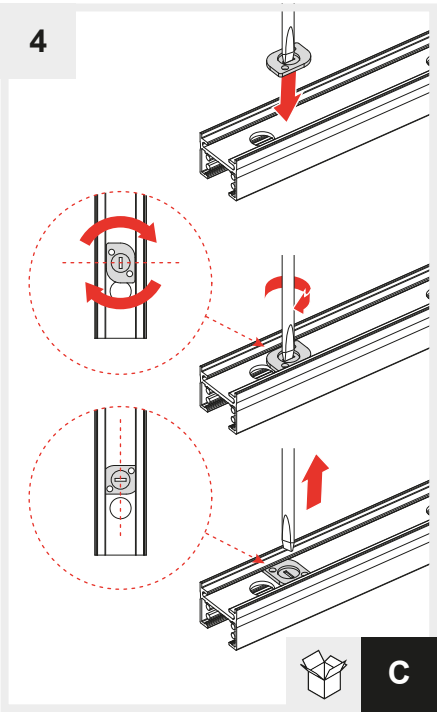

5

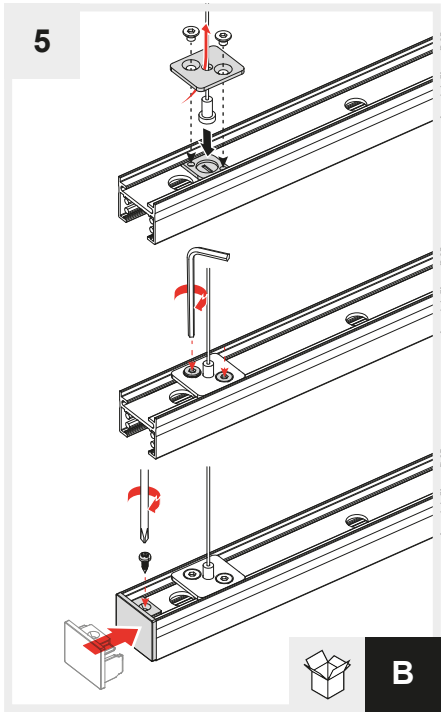

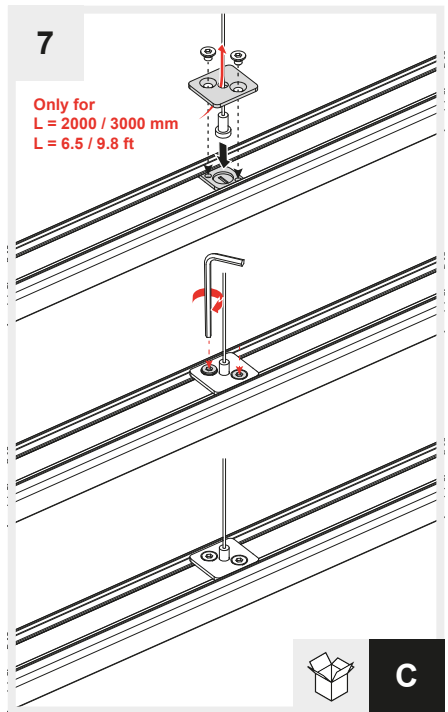
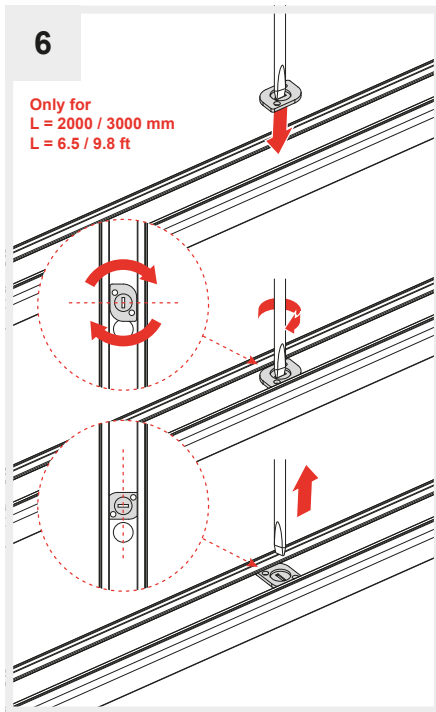

**C**

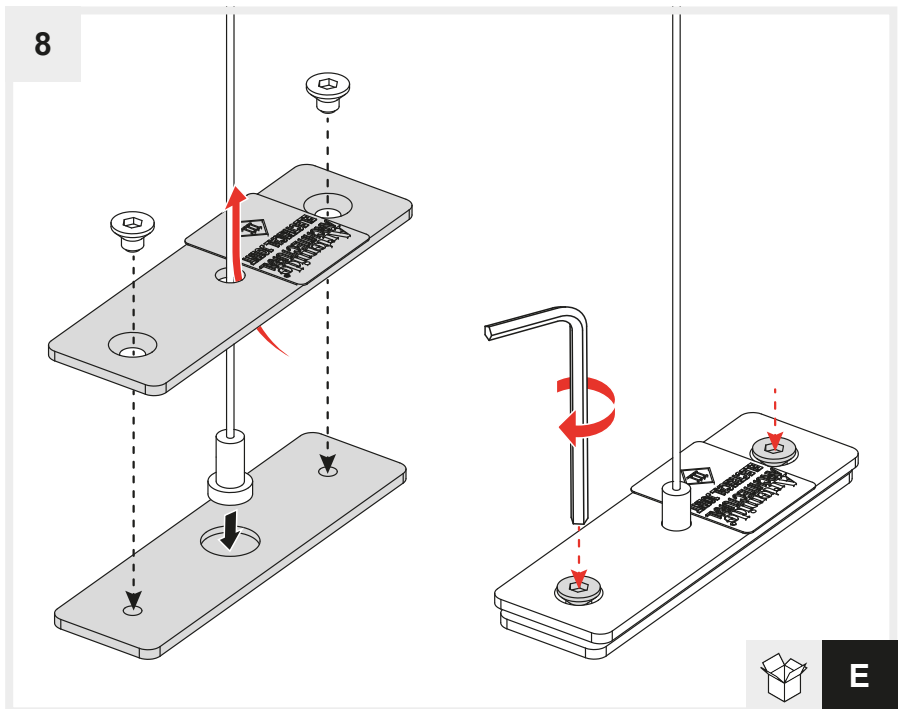

**E**

9

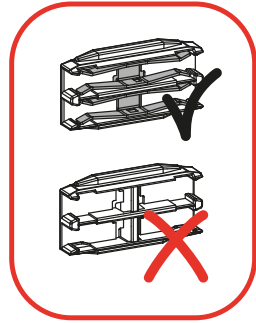
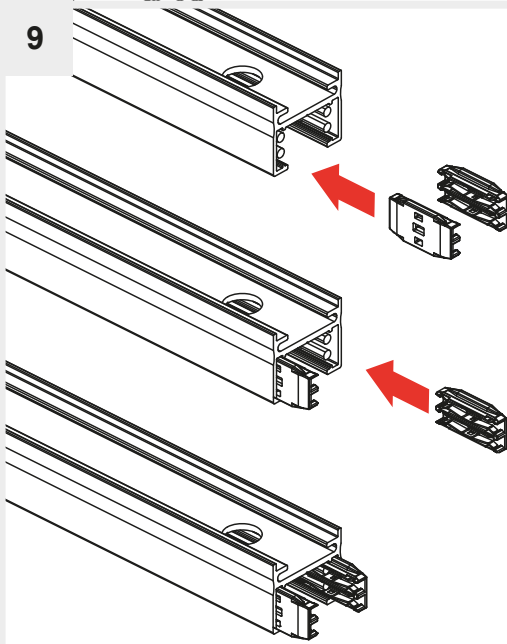

E

10

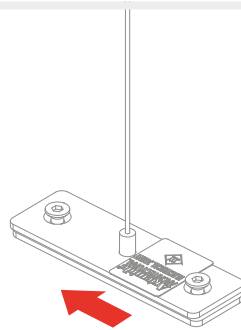
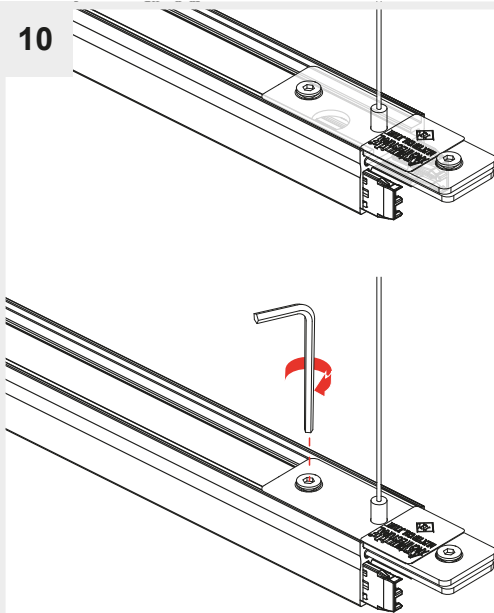

E

11

 → **D1** **D2** **D3** **D4**

Only for  
L = 2000 / 3000 mm  
L = 6.5 / 9.8 ft

Fig. 12 > 16

1<sup>st</sup> module



**B**

12

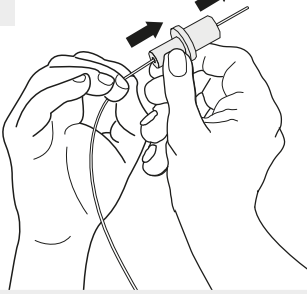

13

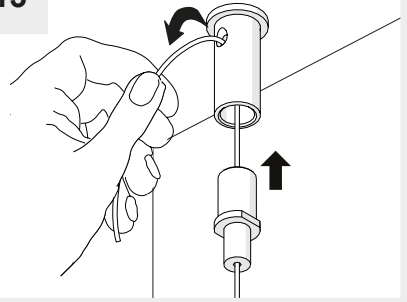

14

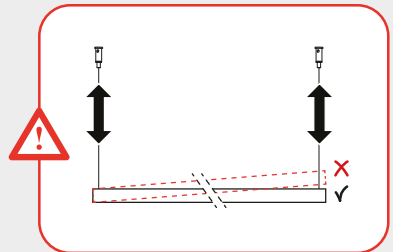
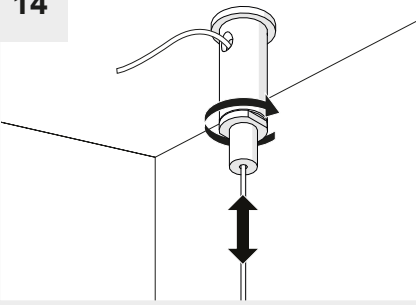



15

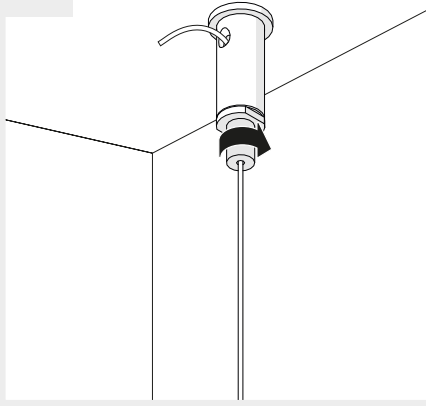

16

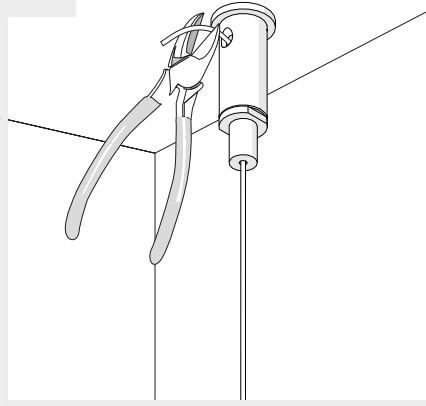

17

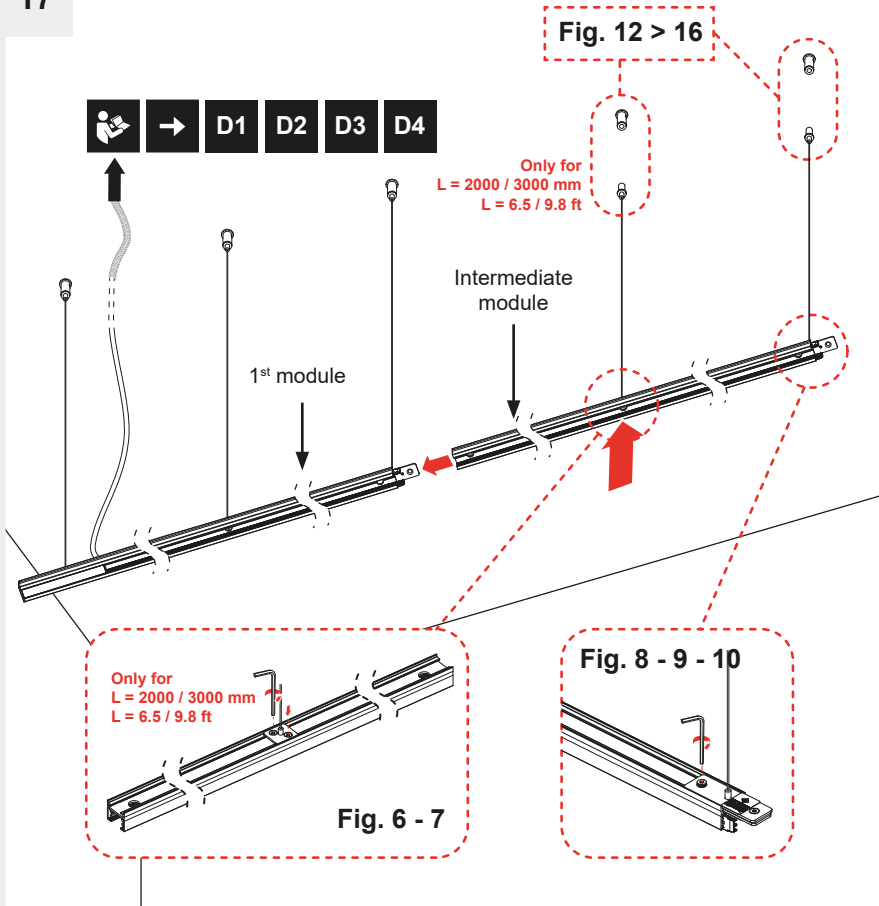

18

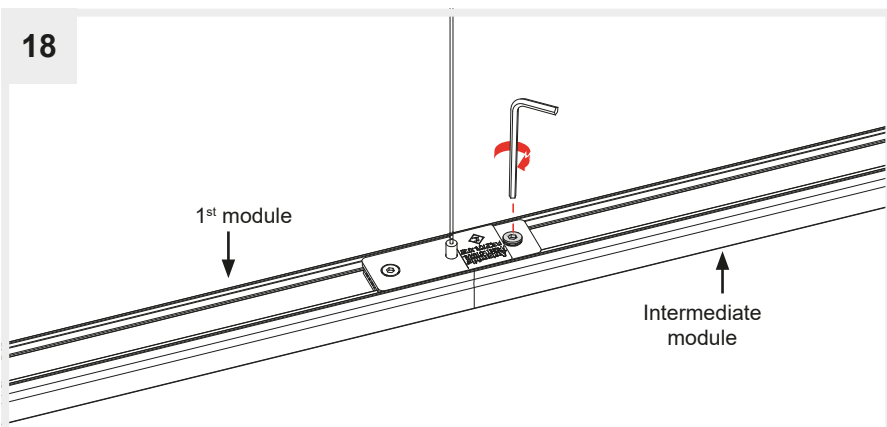

19

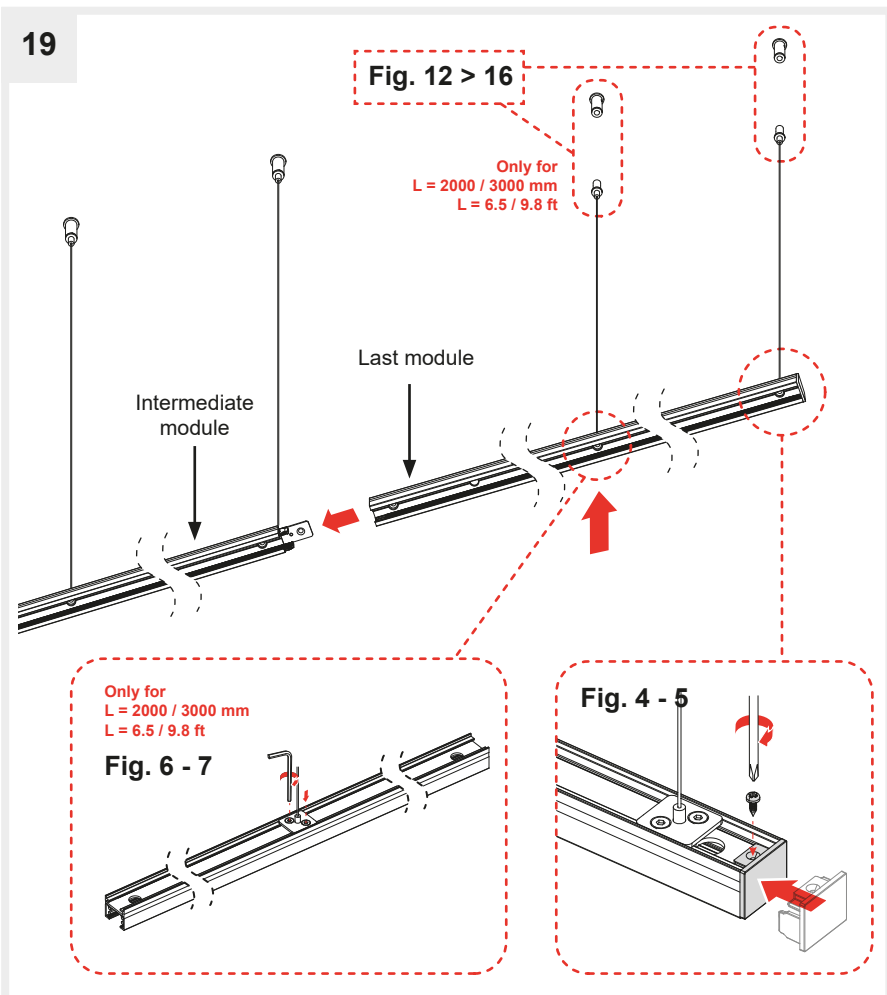

20

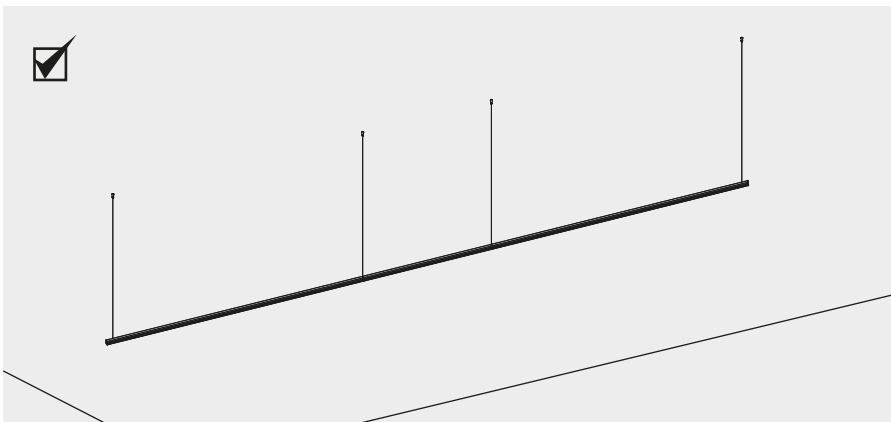
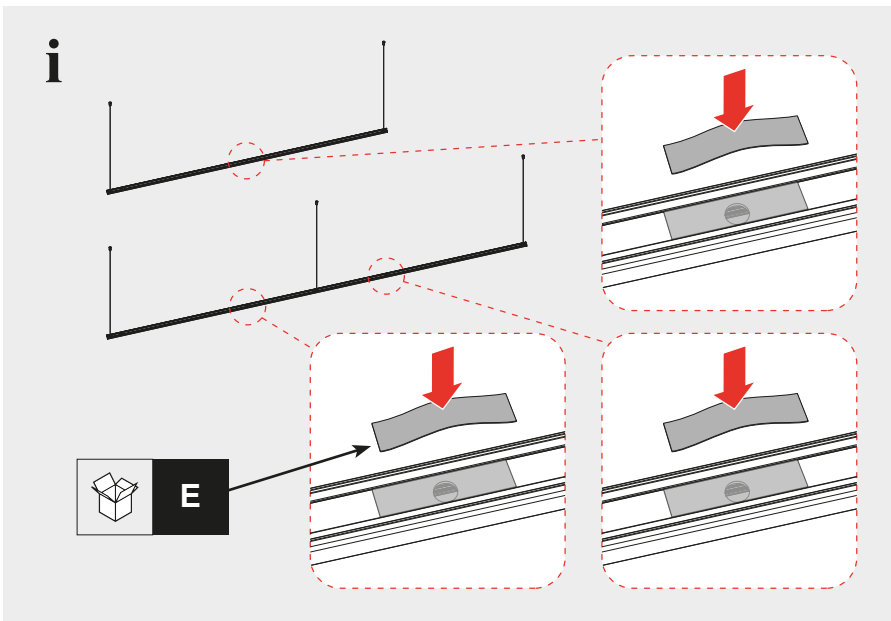
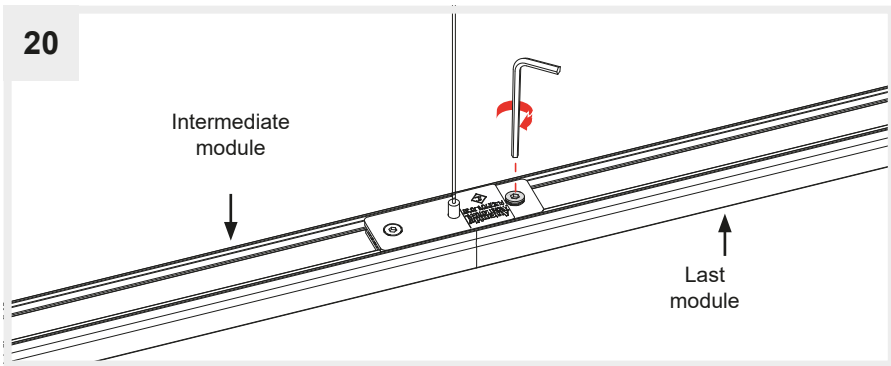

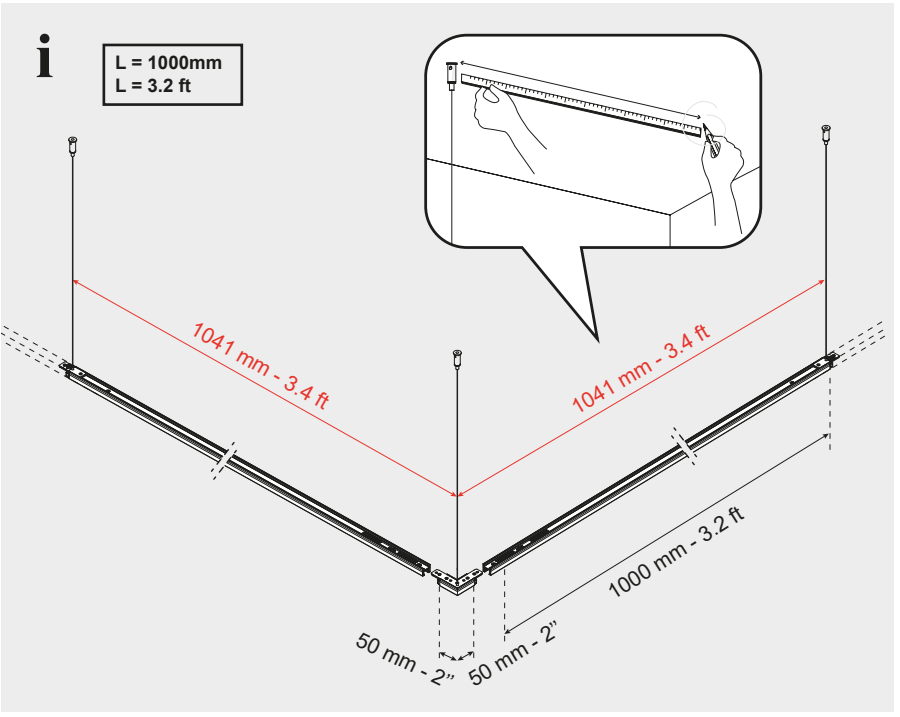
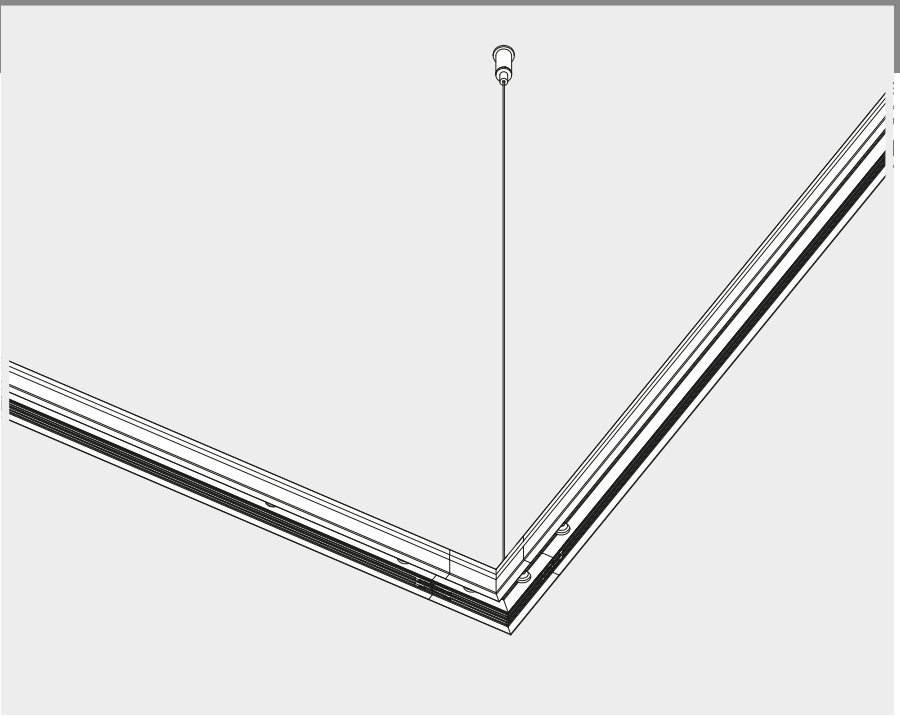

**i**

L = 2000 mm / 3000 mm  
L = 6.5 ft / 9.8 ft

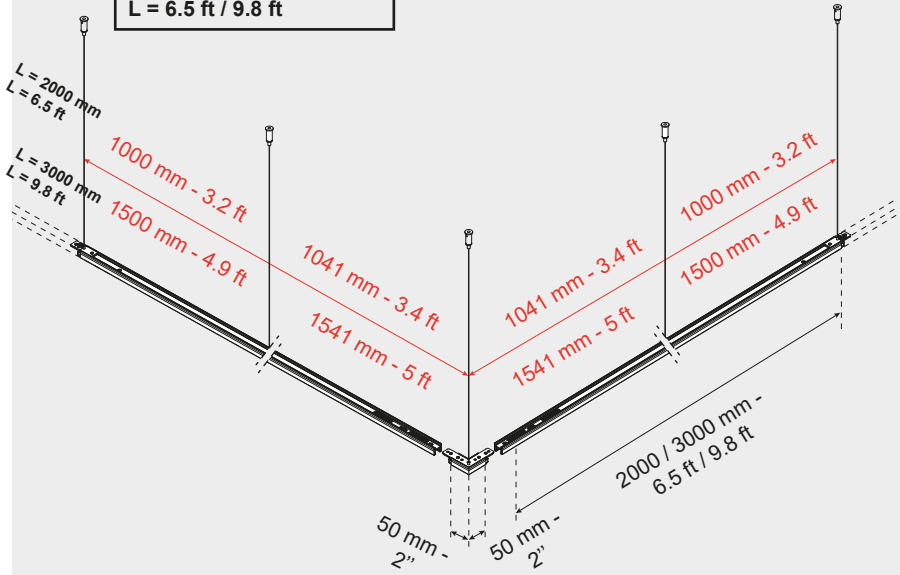

**21**

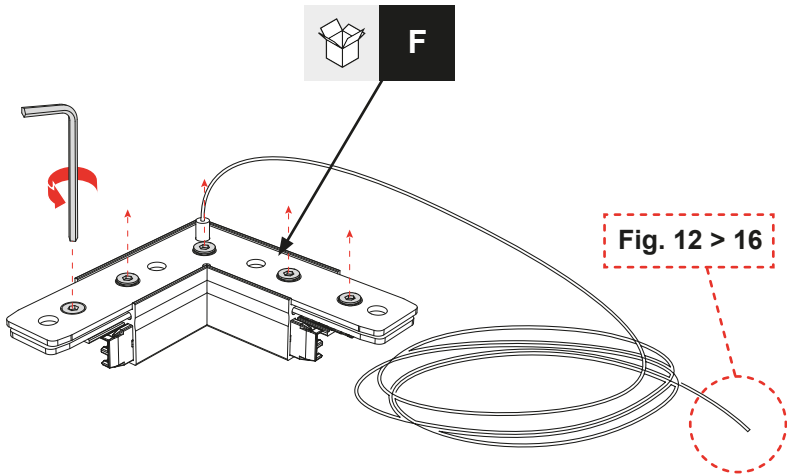

22

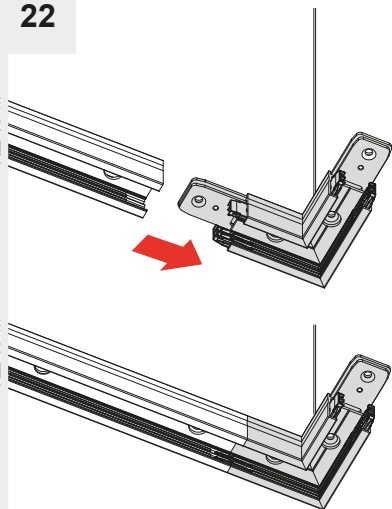

23

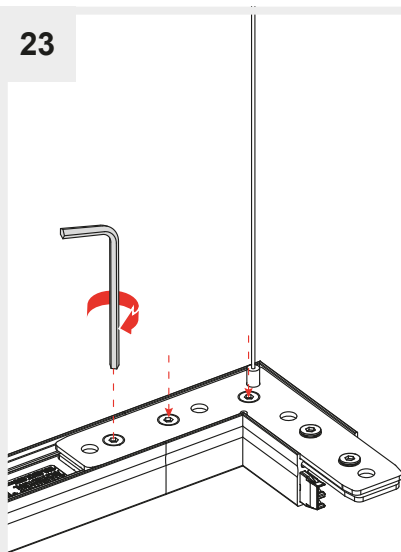

24

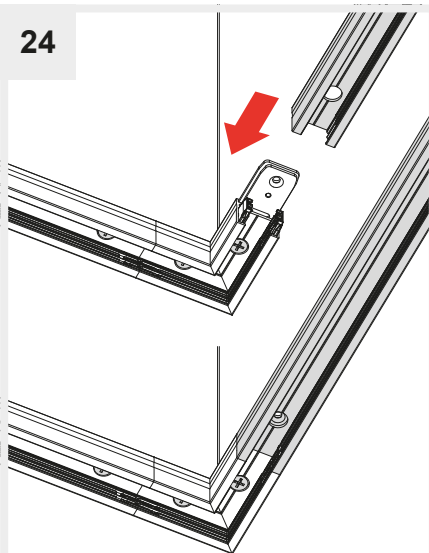

25

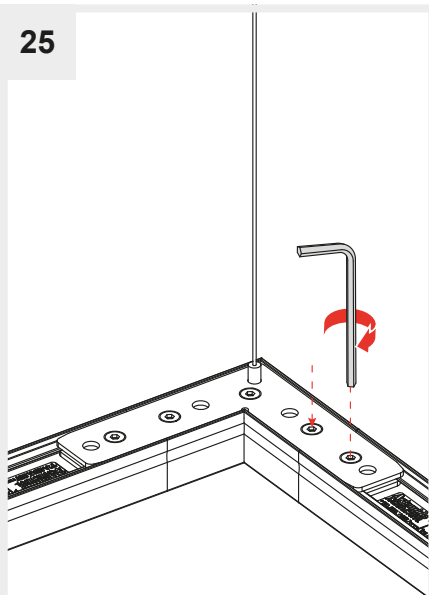

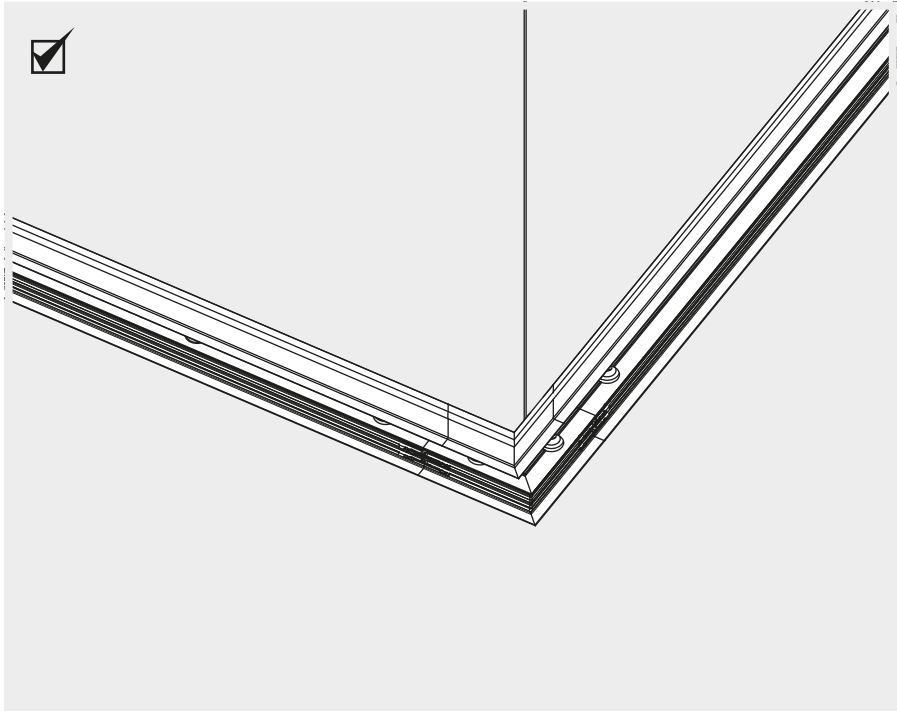



i

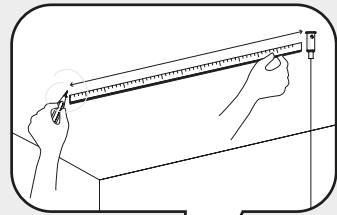
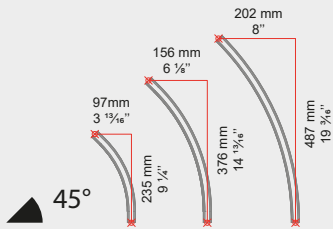

R 300mm - 11 13/16" → TA40022  
 R 500mm - 19 11/16" → TA40122  
 R 700mm - 27 9/16" → TA40222

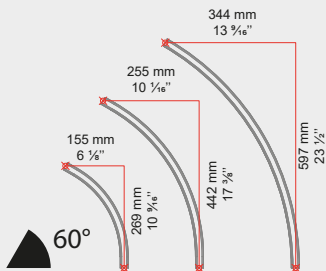

R 300mm - 11 13/16" → TA40322  
 R 500mm - 19 11/16" → TA40422  
 R 700mm - 27 9/16" → TA40522

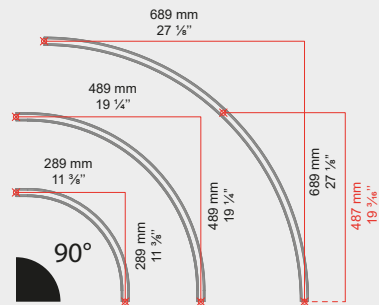

R 300mm - 11 13/16" → TA40622  
 R 500mm - 19 11/16" → TA40722  
 R 700mm - 27 9/16" → TA40822



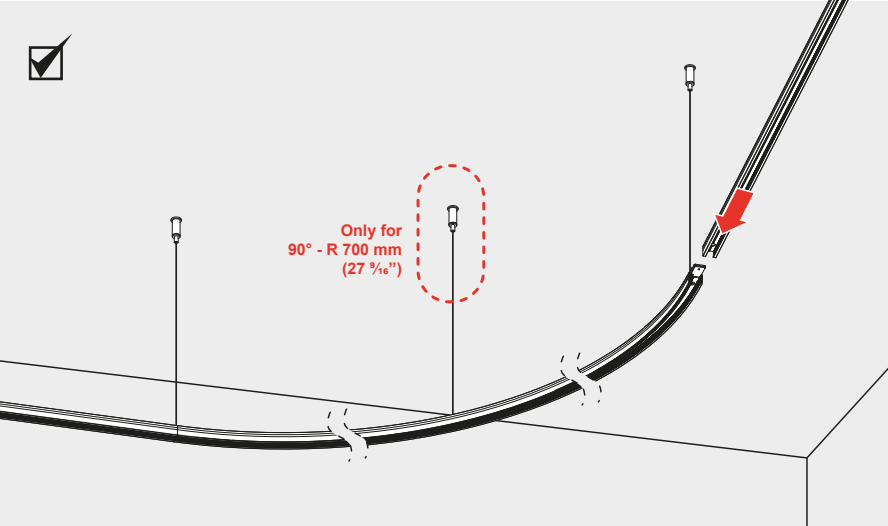
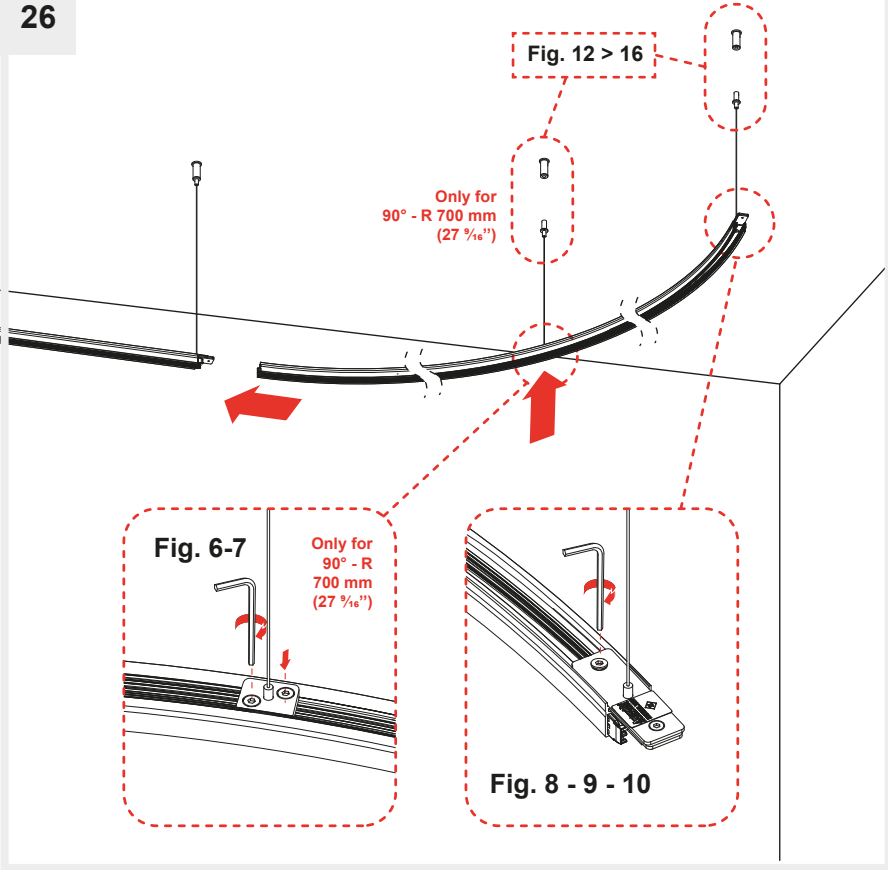

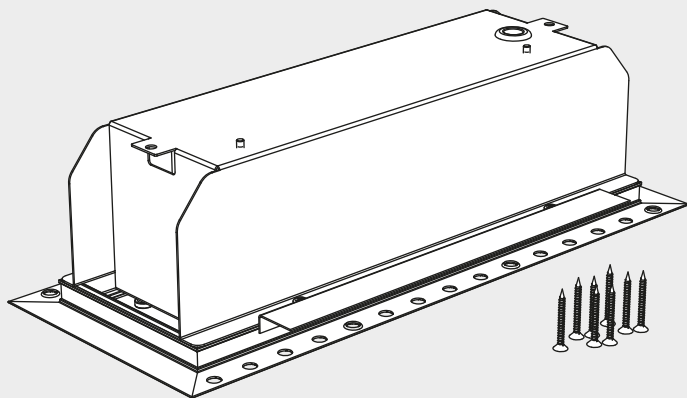

27

$L + 10 \text{ mm}$   
 $L + \frac{25}{64}''$

$a + 10 \text{ mm}$   
 $a + \frac{25}{64}''$

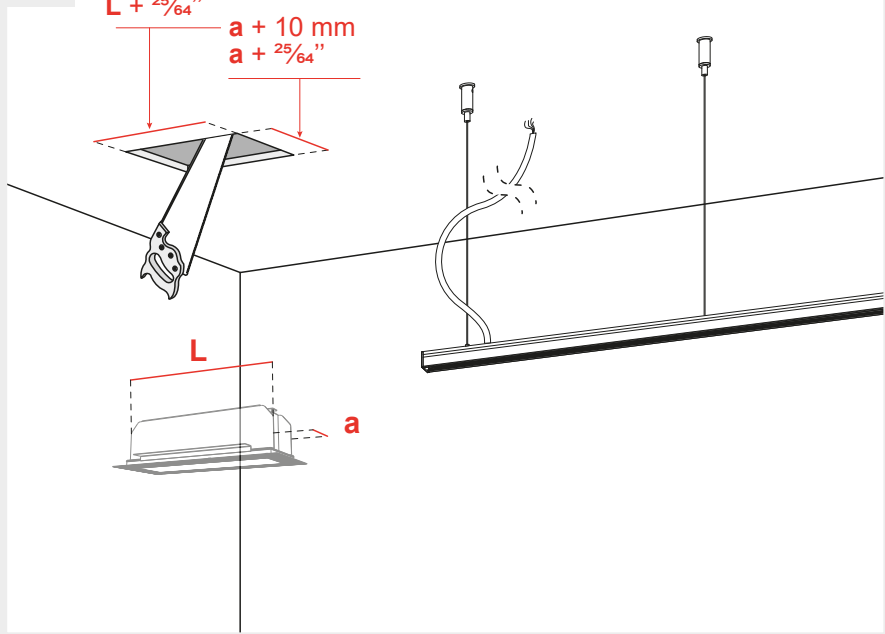

28

**d < 2300 mm - 7.5 ft**

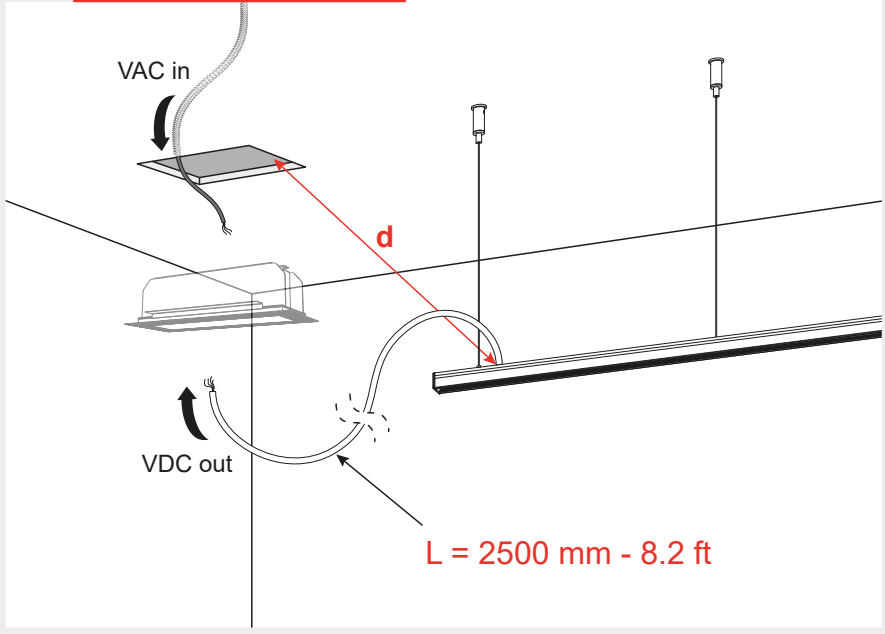

**i**

**d < 2300 mm - 7.5 ft**

Output Max	Max configuration length powerable with standard power cable L = 2500 mm	
[W]	[m]	[ft]
125	97	318
210	54	177

	Standard power cable colours					Cable cross section	
	EN	IT	ES	FR	DE	AWG	[mm <sup>2</sup> ]
DART-	Purple	Viola	Morado	Pourpre	Lila	20	0.5
DART+	Orange	Arancione	Naranja	Orange	Orange	20	0.5
-	Black	Nero	Negro	Noir	Schwarz	16	1.5
+	Red	Rosso	Rojo	Rouge	Rot	16	1.5



29

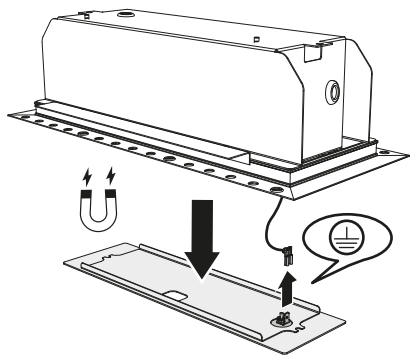

30

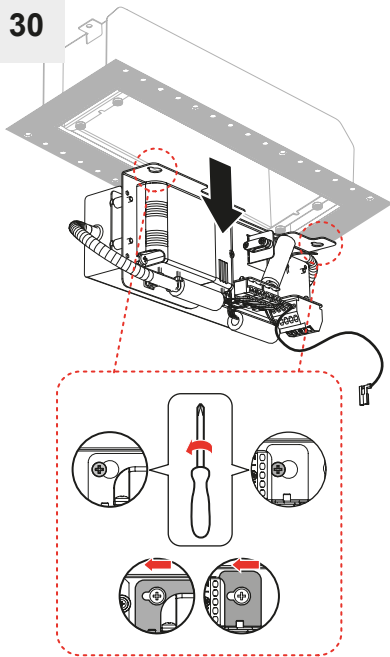

31

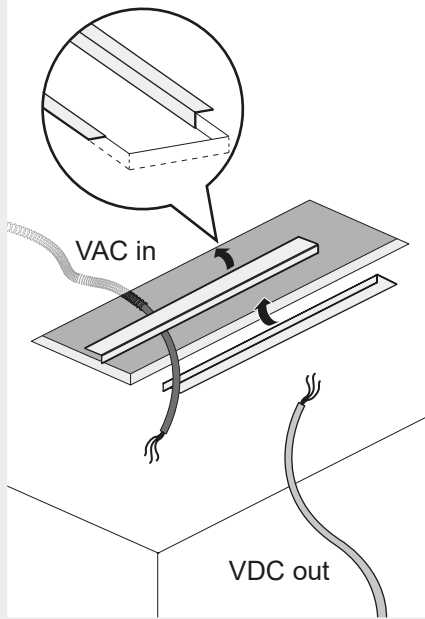

32

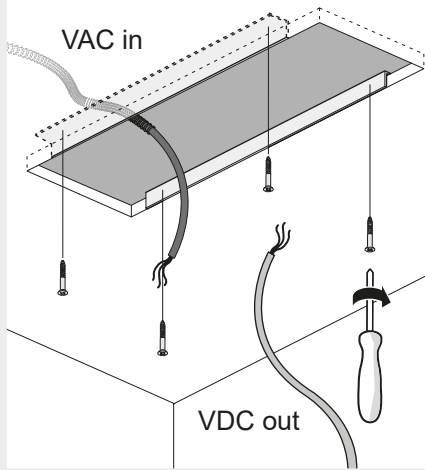

33

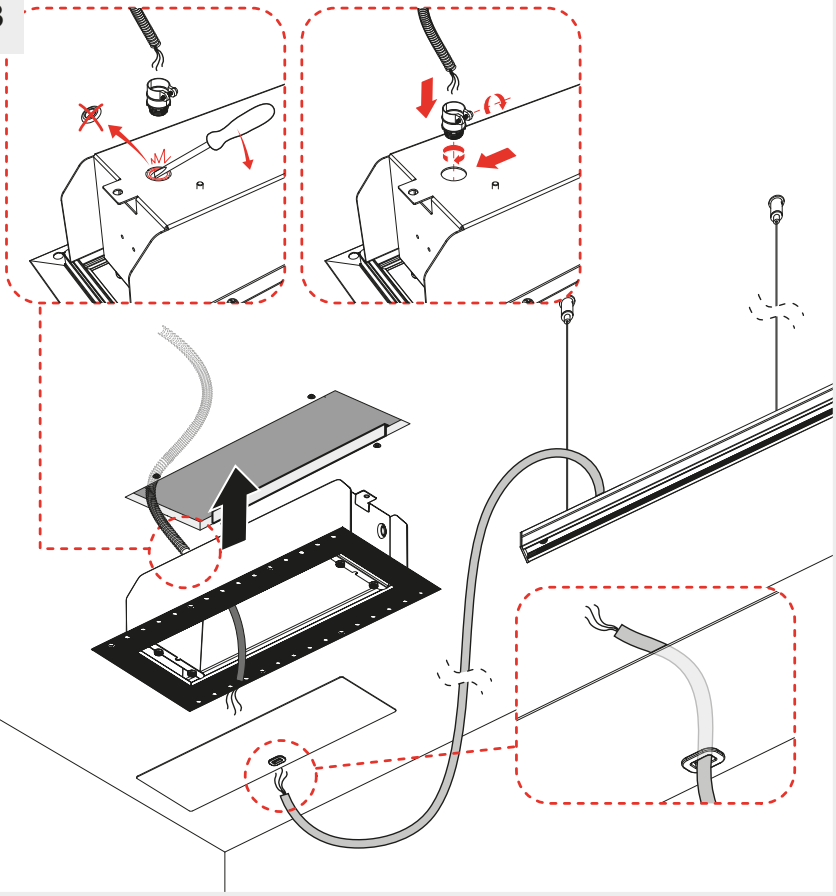

34

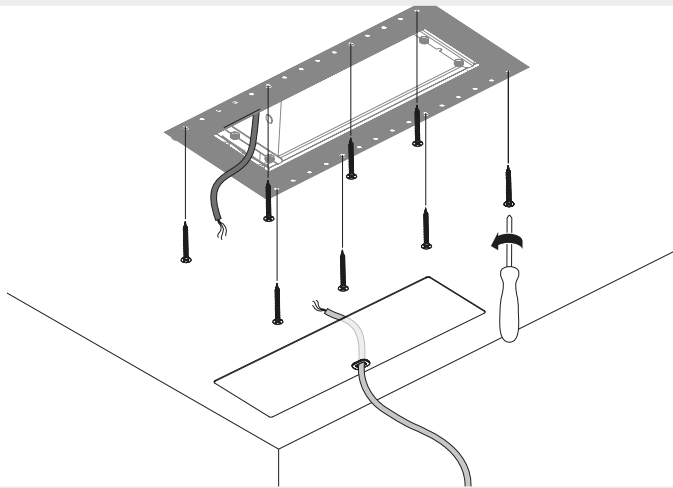

35

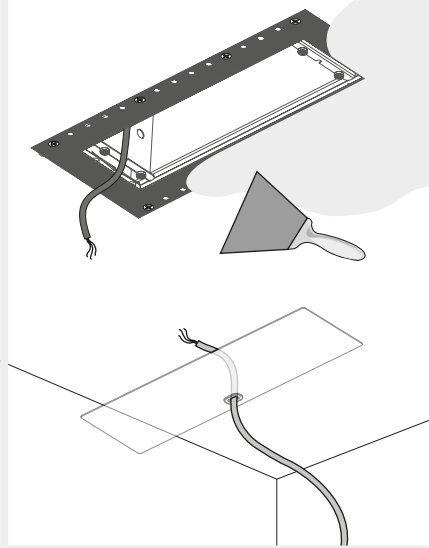

36

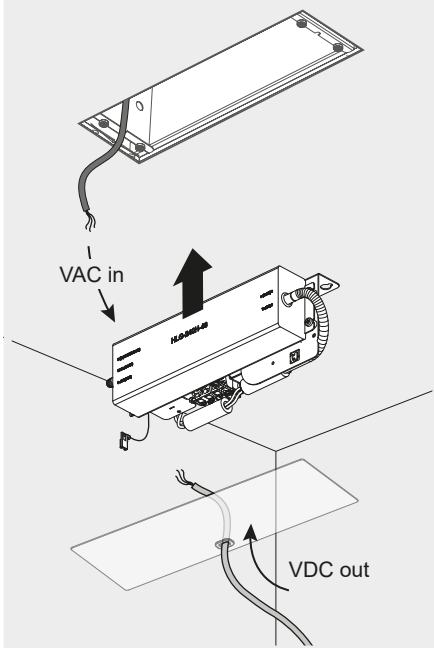







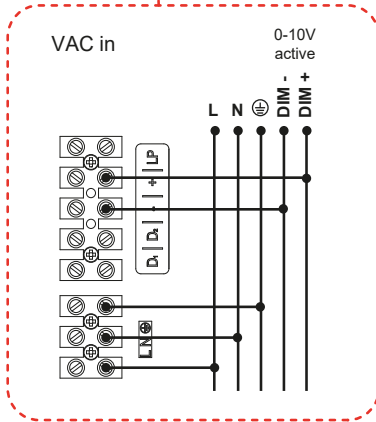
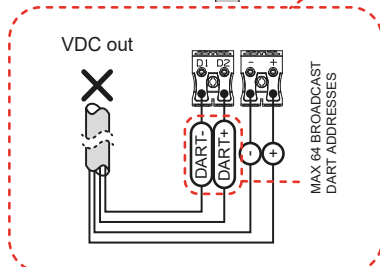
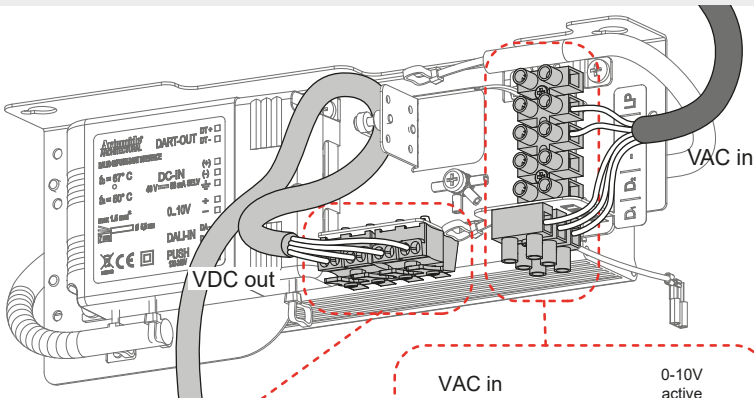
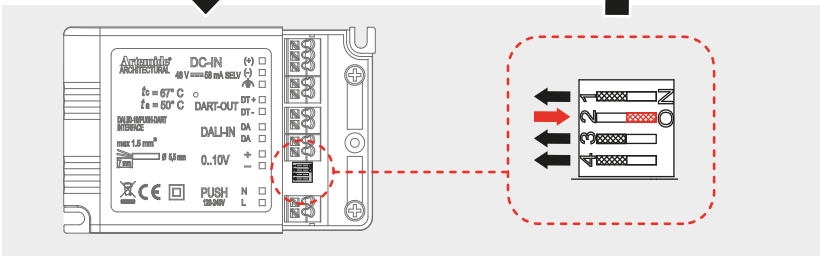
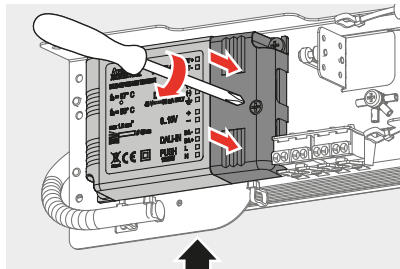
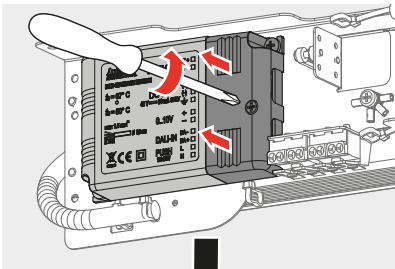

Fig. 37		0-10V	Only for TA622018, TA624018
Fig. 38		Potentiometer	
Fig. 39		DALI	
Fig. 40		1-10V	
Fig. 41		Push	
Fig. 42		LV Push	
Fig. 43		APP	



**DART = DALI SELV**



	EN	IT	ES	FR	DE
DART-	Purple	Viola	Morado	Pourpre	Lila
DART+	Orange	Aranzone	Naranja	Orange	Orange
-	Black	Nero	Negro	Noir	Schwarz
+	Red	Rosso	Rojo	Rouge	Rot

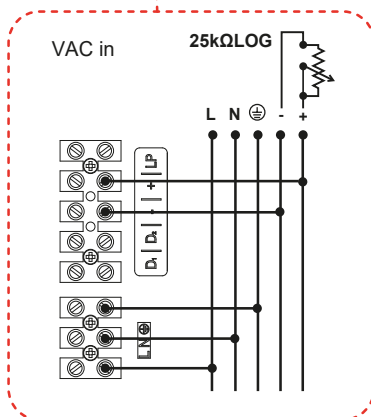
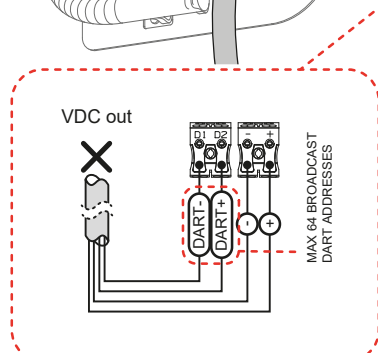
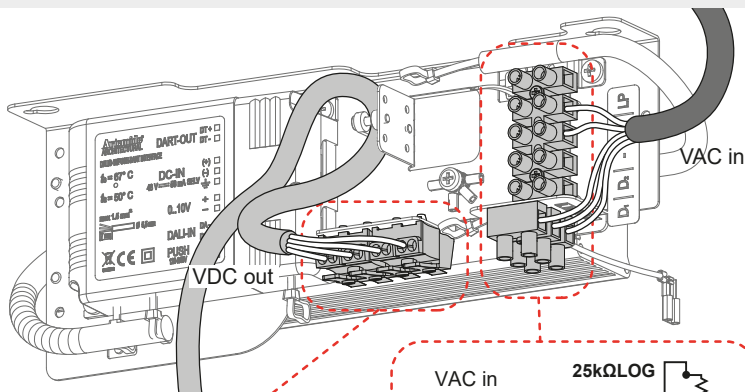
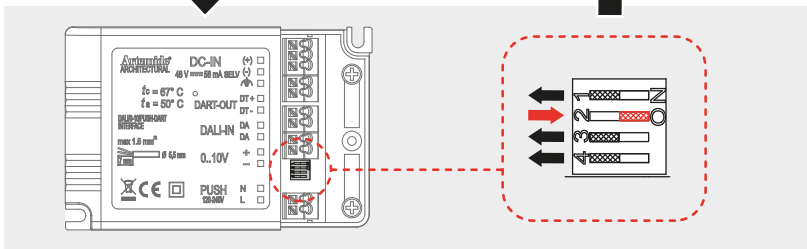
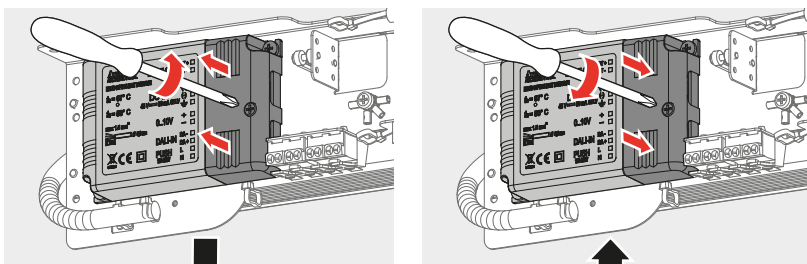

	EN	IT	ES	FR	DE
<b>DART-</b>	Purple	Viola	Morado	Pourpre	Lila
<b>DART+</b>	Orange	Arancione	Naranja	Orange	Orange
<b>-</b>	Black	Nero	Negro	Noir	Schwarz
<b>+</b>	Red	Rosso	Rojo	Rouge	Rot





Only for TA622018, TA624018

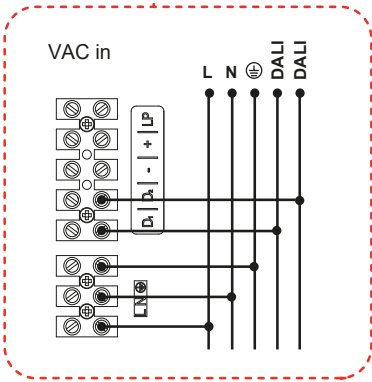
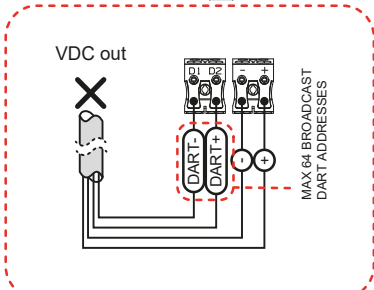
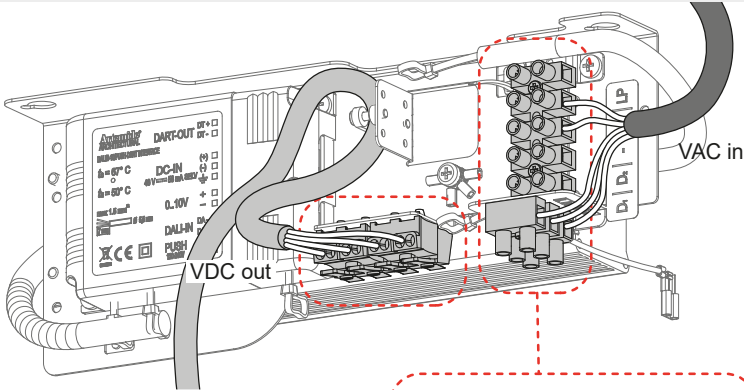
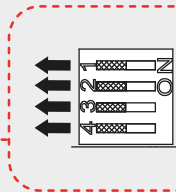
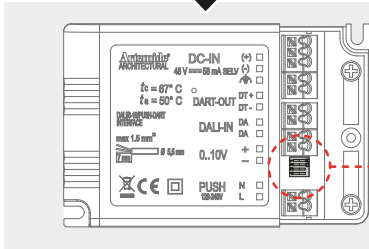
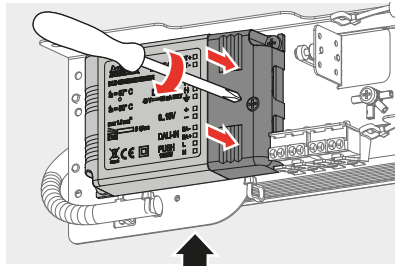
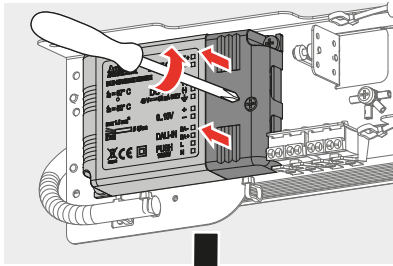

	EN	IT	ES	FR	DE
DART-	Purple	Viola	Morado	Pourpre	Lila
DART+	Orange	Arancione	Naranja	Orange	Orange
-	Black	Nero	Negro	Noir	Schwarz
+	Red	Rosso	Rojo	Rouge	Rot

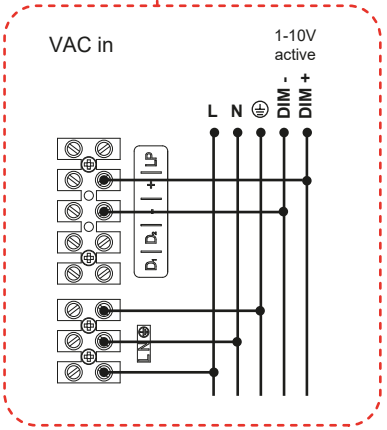
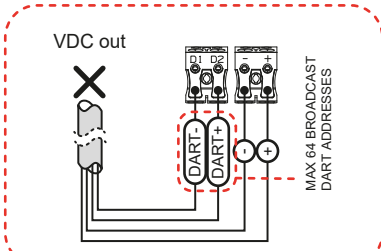
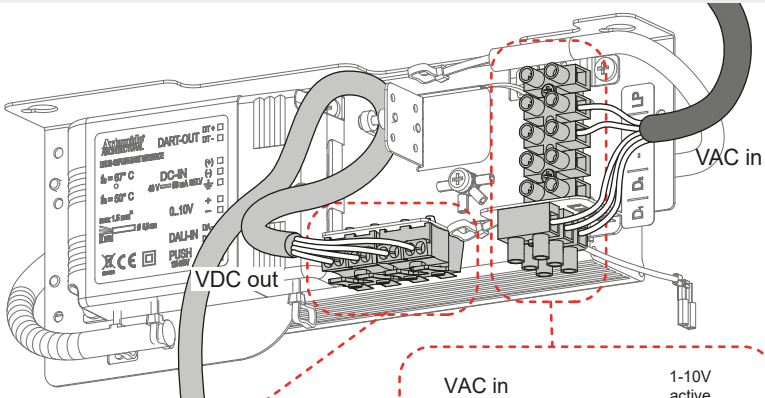
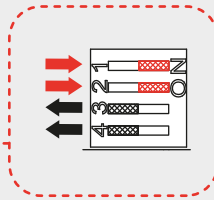
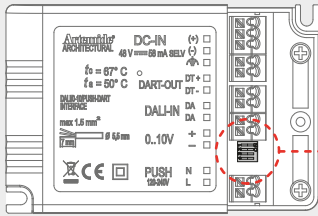
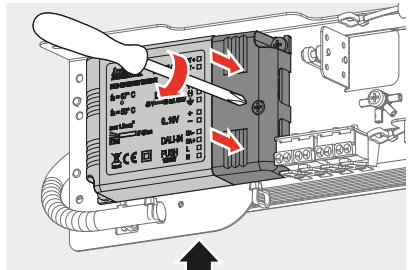
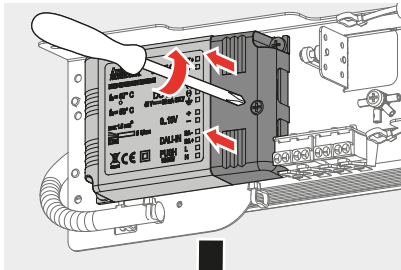

	EN	IT	ES	FR	DE
<b>DART-</b>	Purple	Viola	Morado	Pourpre	Lila
<b>DART+</b>	Orange	Arancione	Naranja	Orange	Orange
<b>-</b>	Black	Nero	Negro	Noir	Schwarz
<b>+</b>	Red	Rosso	Rojo	Rouge	Rot



Only for TA622018, TA624018

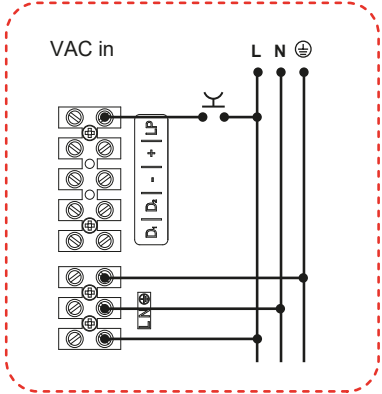
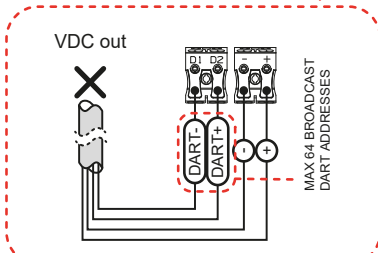
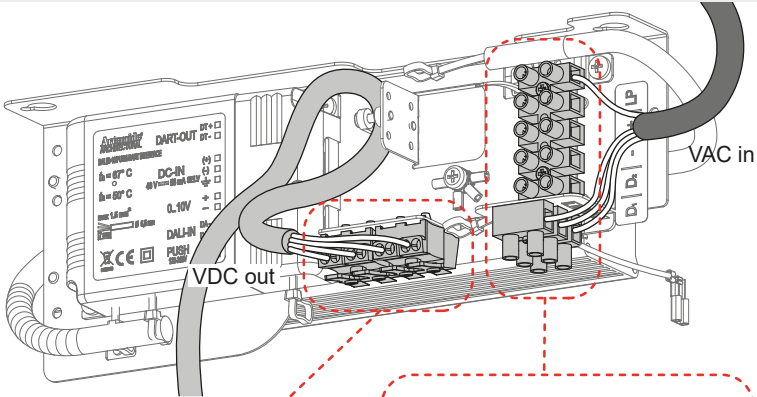
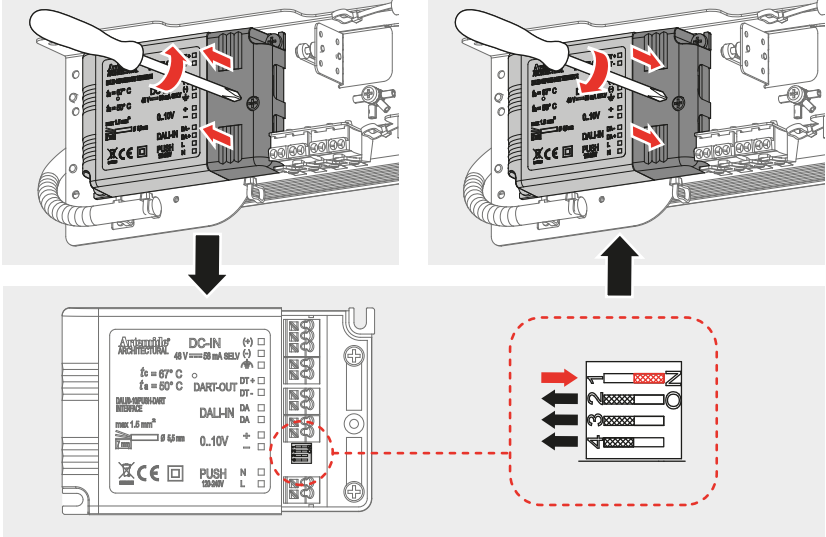

	EN	IT	ES	FR	DE
DART-	Purple	Viola	Morado	Pourpre	Lila
DART+	Orange	Arancione	Naranja	Orange	Orange
-	Black	Nero	Negro	Noir	Schwarz
+	Red	Rosso	Rojo	Rouge	Rot

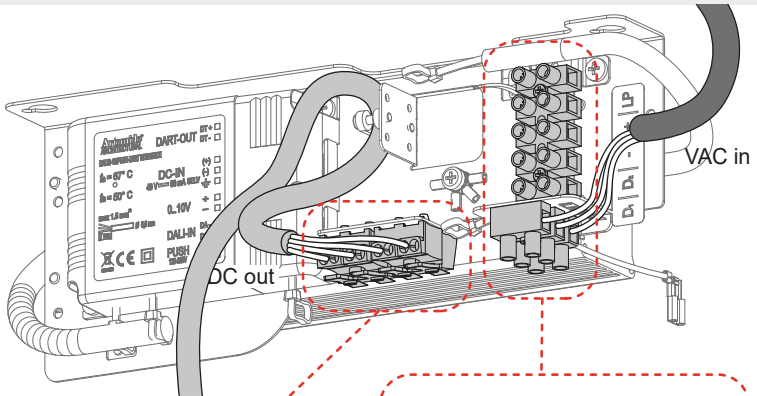
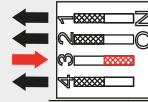
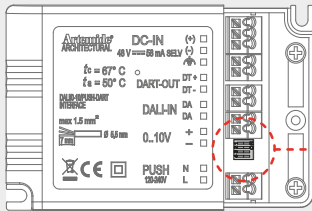
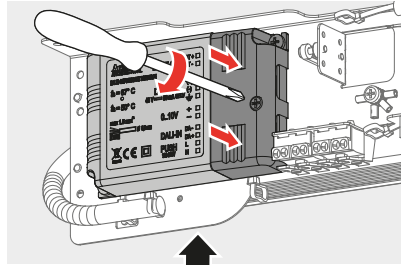
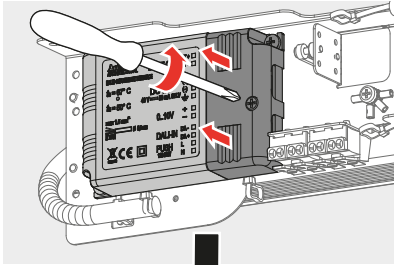

VDC out

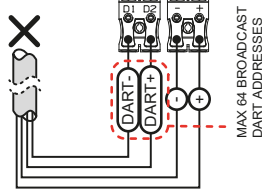

VAC in

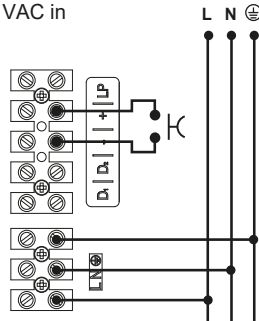

	EN	IT	ES	FR	DE
DART-	Purple	Viola	Morado	Pourpre	Lila
DART+	Orange	Arancione	Naranja	Orange	Orange
-	Black	Nero	Negro	Noir	Schwarz
+	Red	Rosso	Rojo	Rouge	Rot

43



Only for TA622018APP, TA624018APP

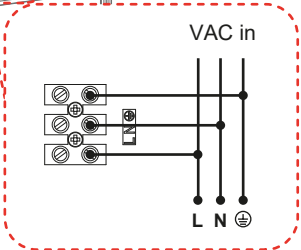
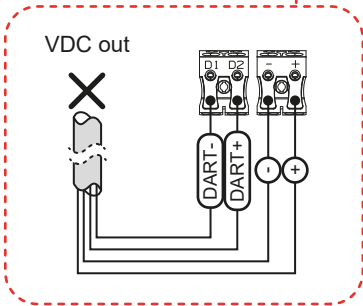
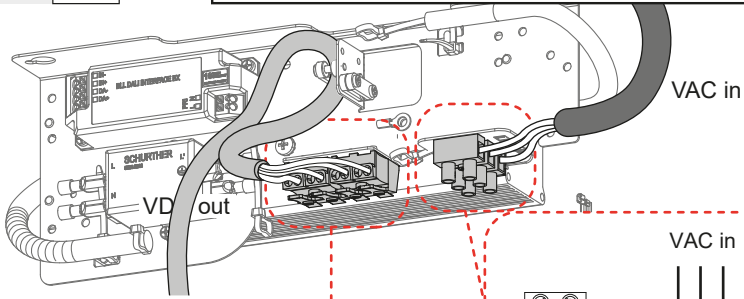

	EN	IT	ES	FR	DE
DART-	Purple	Viola	Morado	Pourpre	Lila
DART+	Orange	Arancione	Naranja	Orange	Orange
-	Black	Nero	Negro	Noir	Schwarz
+	Red	Rosso	Rojo	Rouge	Rot

44

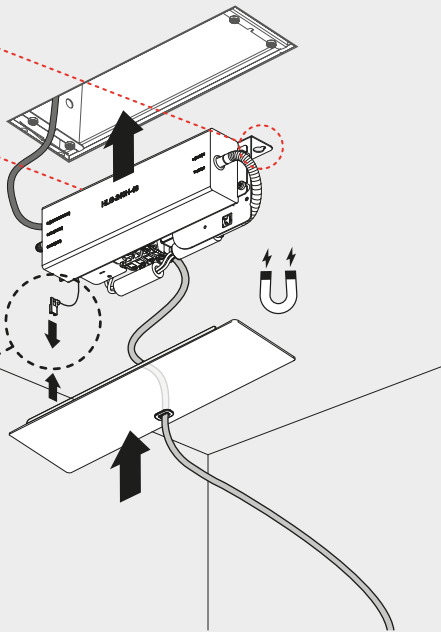
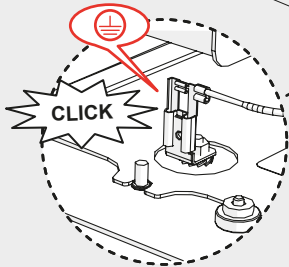
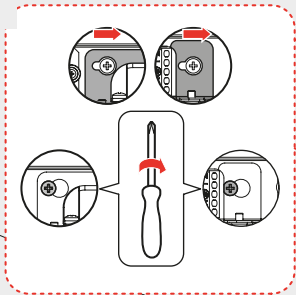



Only for TA622018APP, TA624018APP

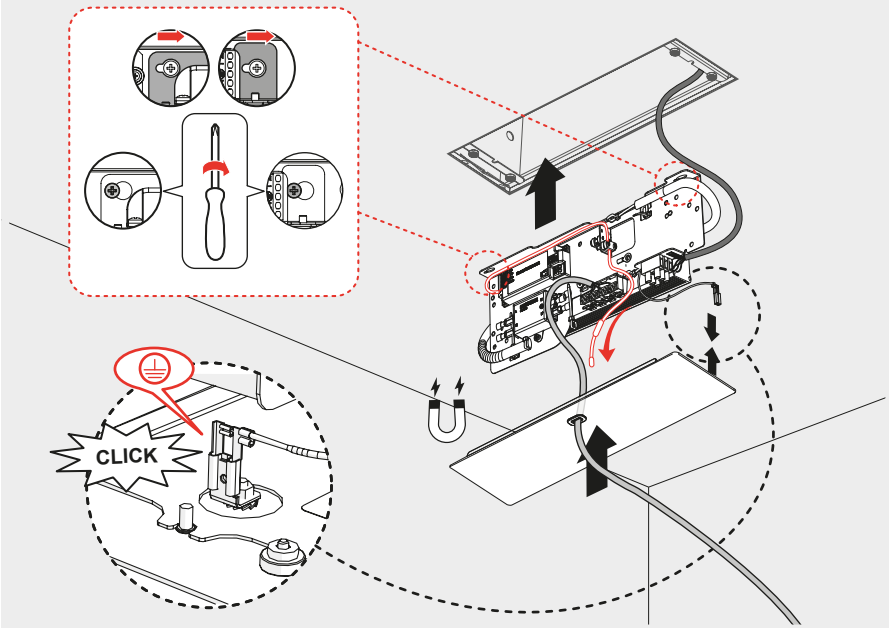

Only for TA622018APP, TA624018APP

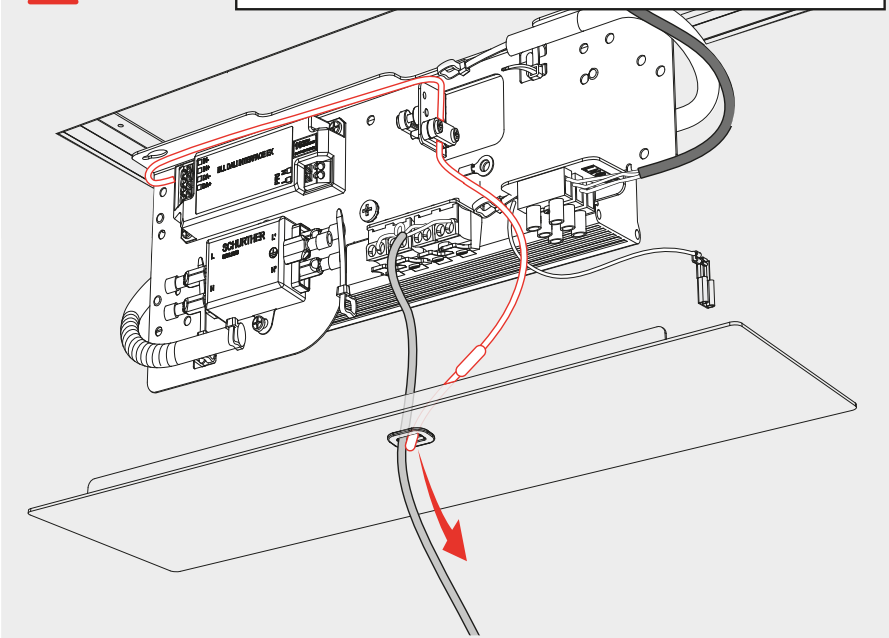

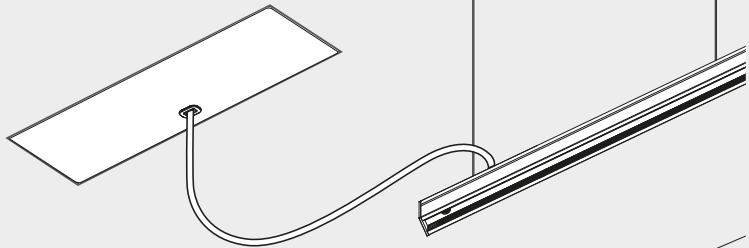

Only for  
TA622018APP,  
TA624018APP

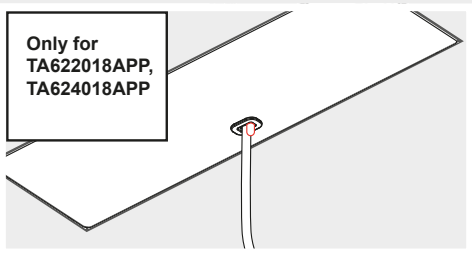

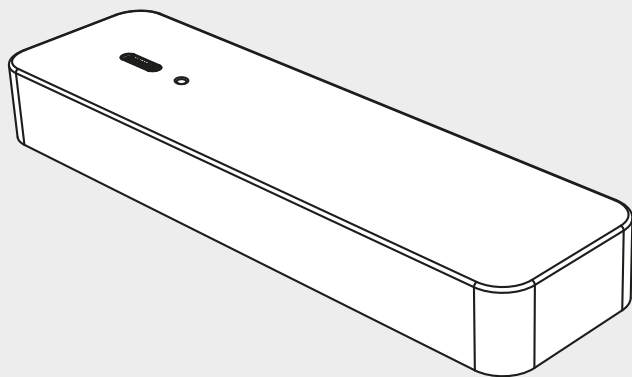

45

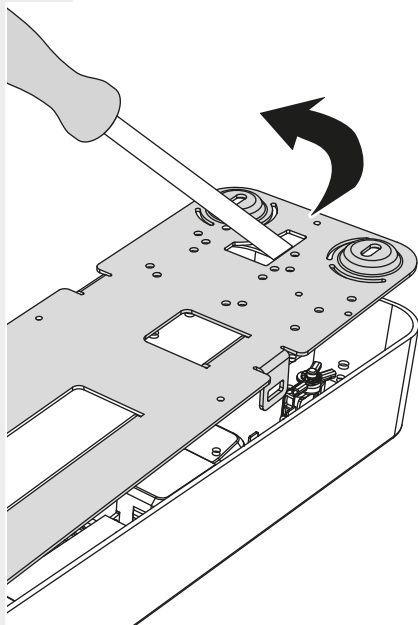

46

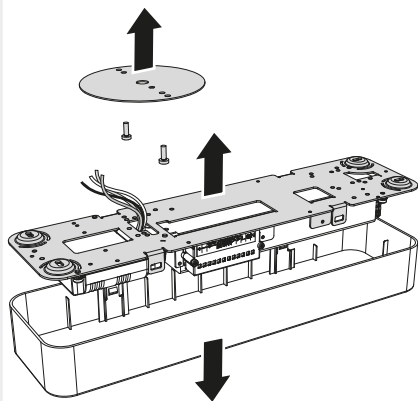



47

**d < 2300 mm - 7.5 ft**

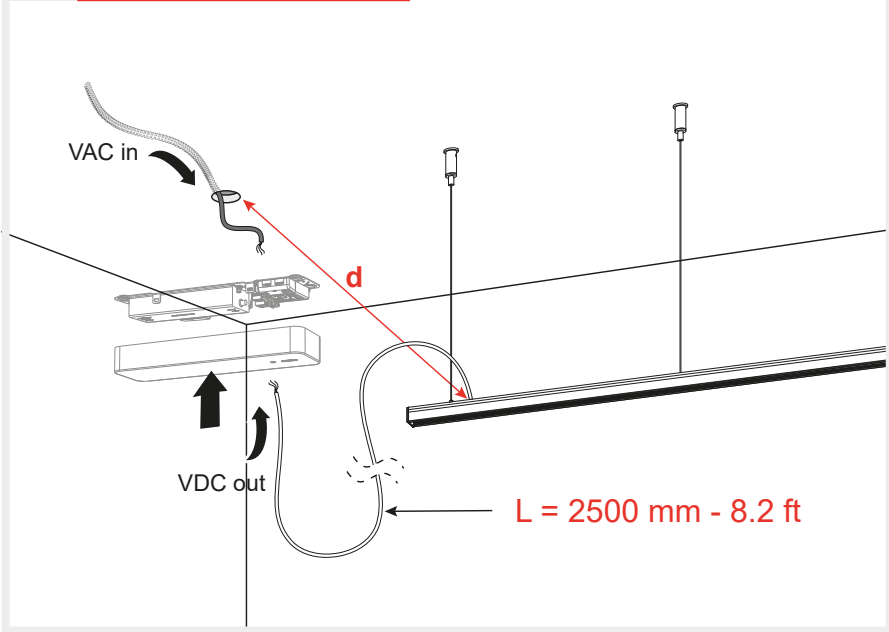

**i**

**d < 2300 mm - 7.5 ft**

Output Max	Max configuration length powerable with standard power cable L = 2500 mm	
	[W]	[m]
125	97	318
210	54	177

	Standard power cable colours					Cable cross section	
	EN	IT	ES	FR	DE	AWG	[mm <sup>2</sup> ]
DART-	Purple	Viola	Morado	Pourpre	Lila	20	0.5
DART+	Orange	Arancione	Naranja	Orange	Orange	20	0.5
-	Black	Nero	Negro	Noir	Schwarz	16	1.5
+	Red	Rosso	Rojo	Rouge	Rot	16	1.5



**i**

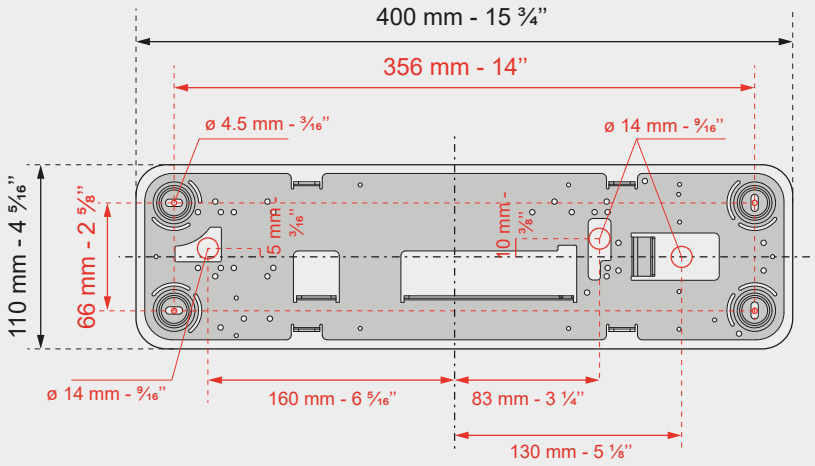





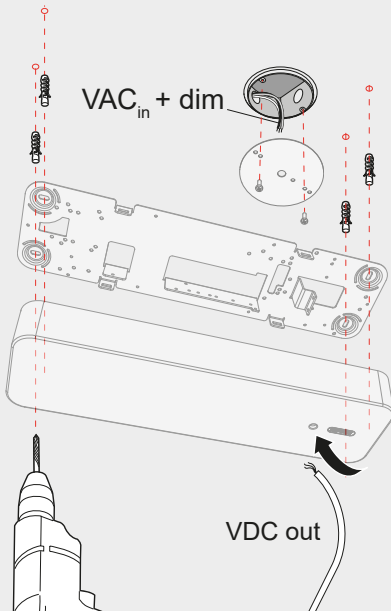

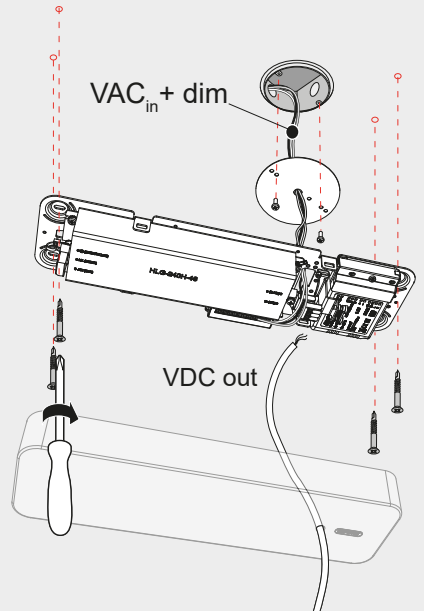

**48**

**i** REQUIRED HARDWARE  
QUINCAILLERIE REQUISE



**49**



<b>Fig. 50</b>		<b>0-10V</b>	<p>Only for TA610018, TA612228, TA614018, TA616228</p>
<b>Fig. 51</b>		<b>Potentiometer</b>	
<b>Fig. 52</b>		<b>DALI</b>	
<b>Fig. 53</b>		<b>1-10V</b>	
<b>Fig. 54</b>		<b>Push</b>	
<b>Fig. 55</b>		<b>LV Push</b>	
<b>Fig. 56</b>		<b>APP</b>	

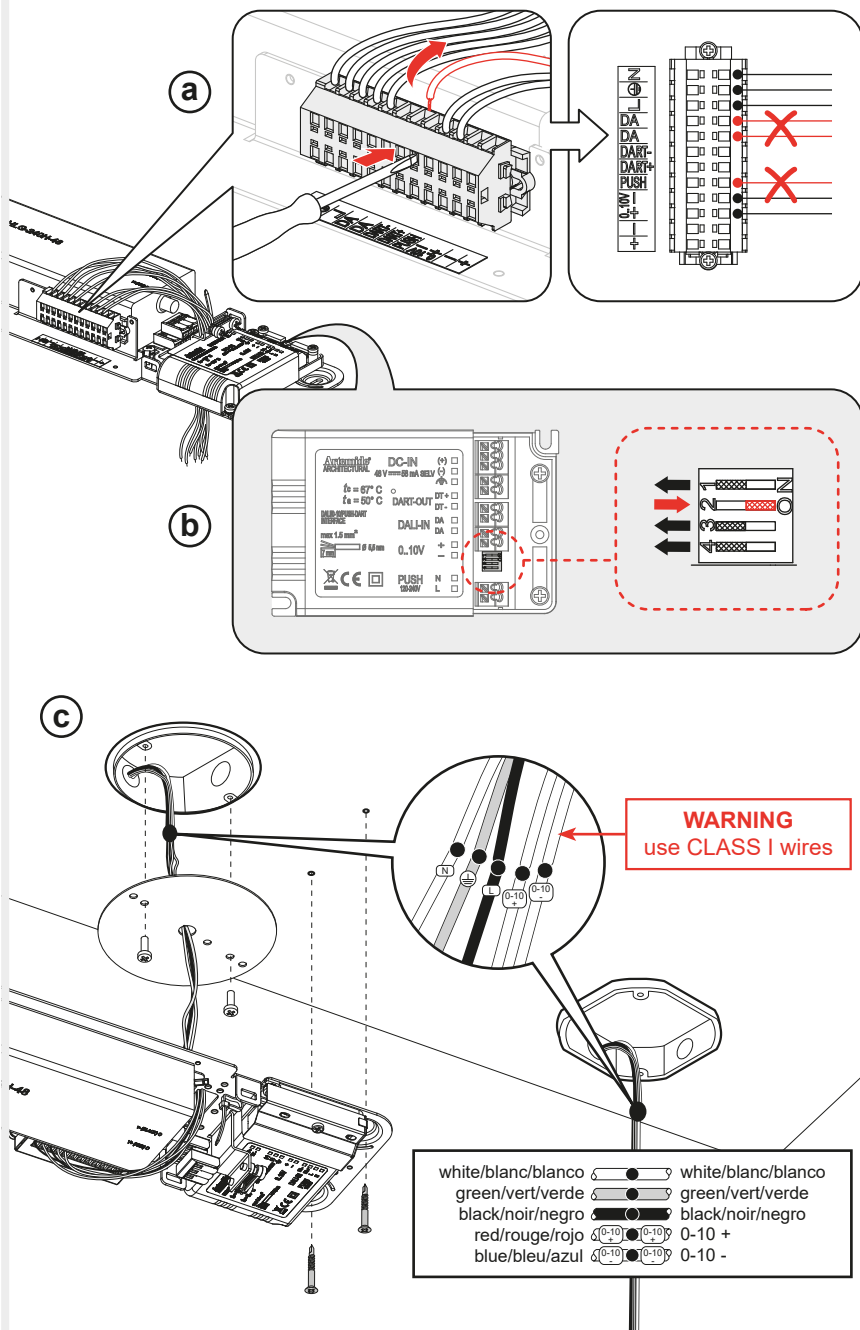

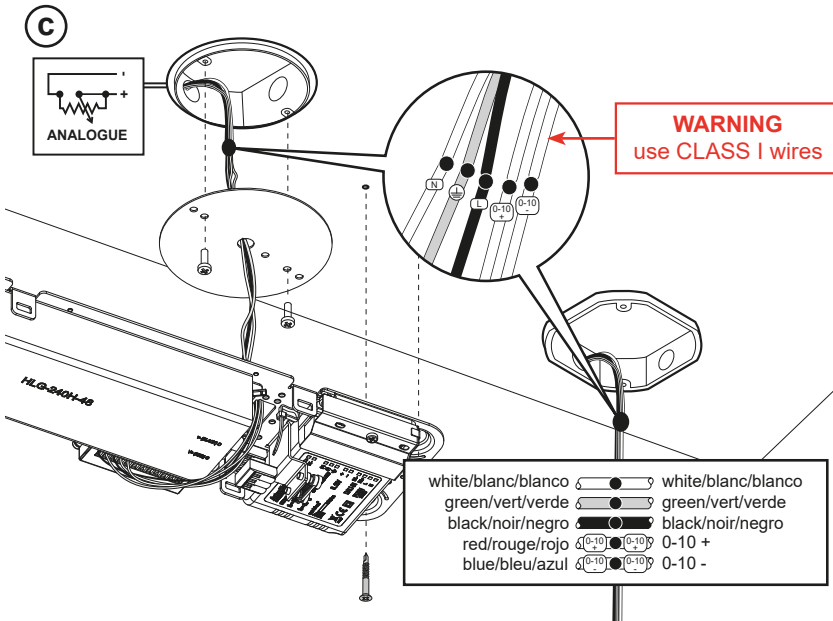
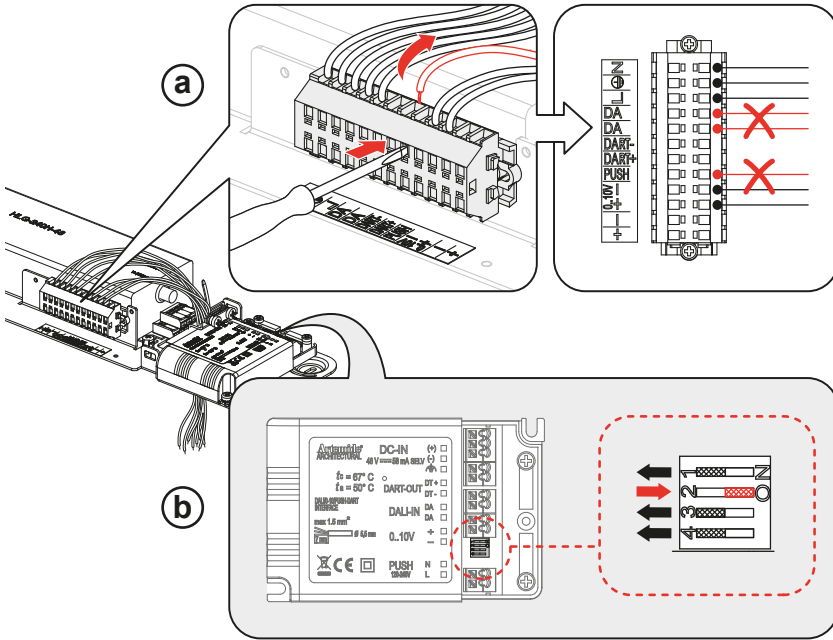

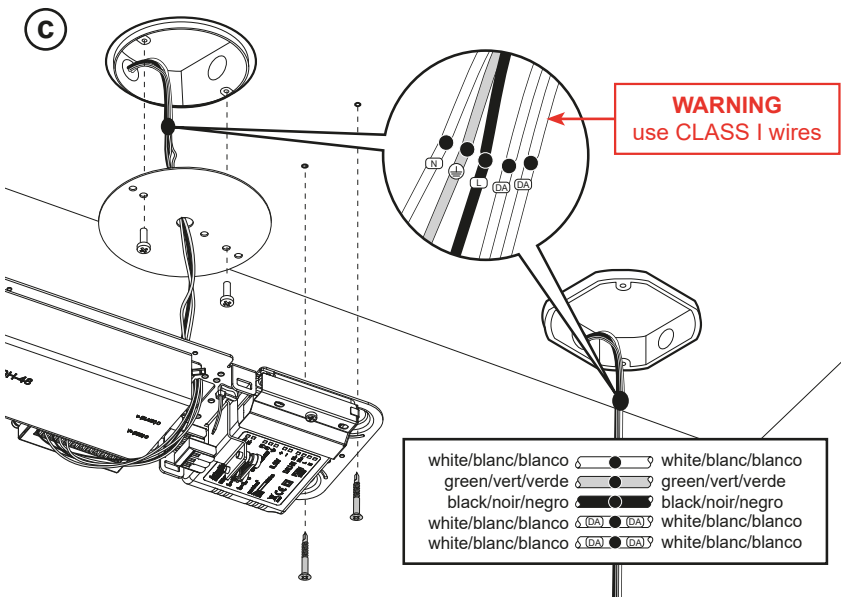
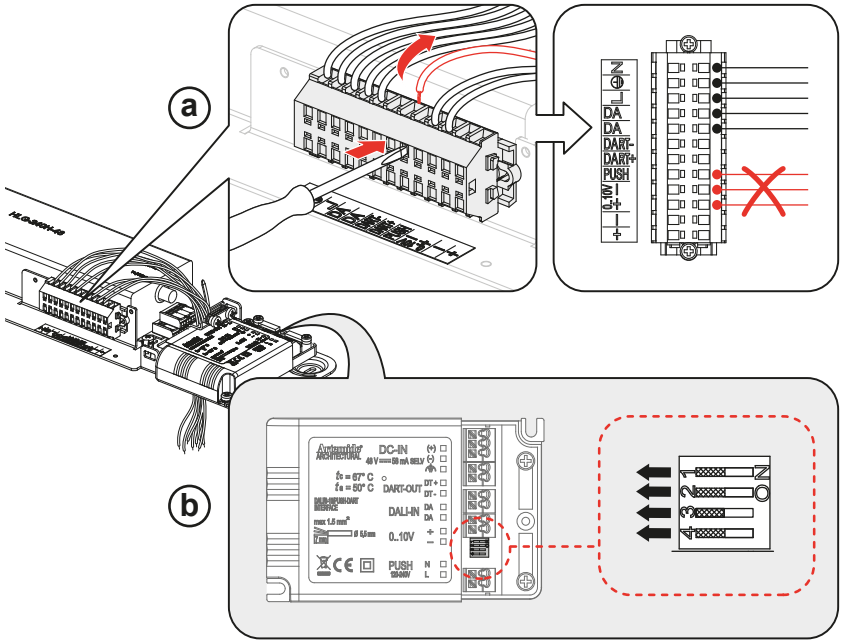

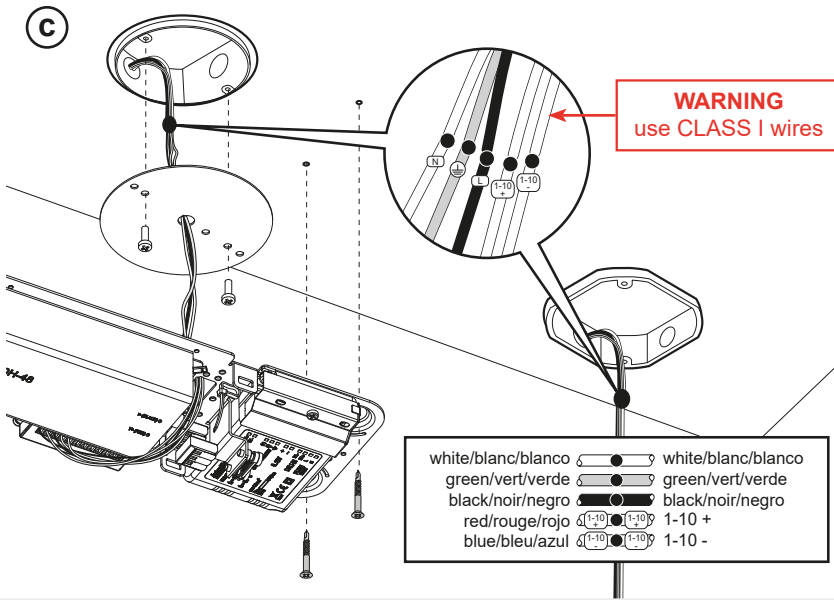
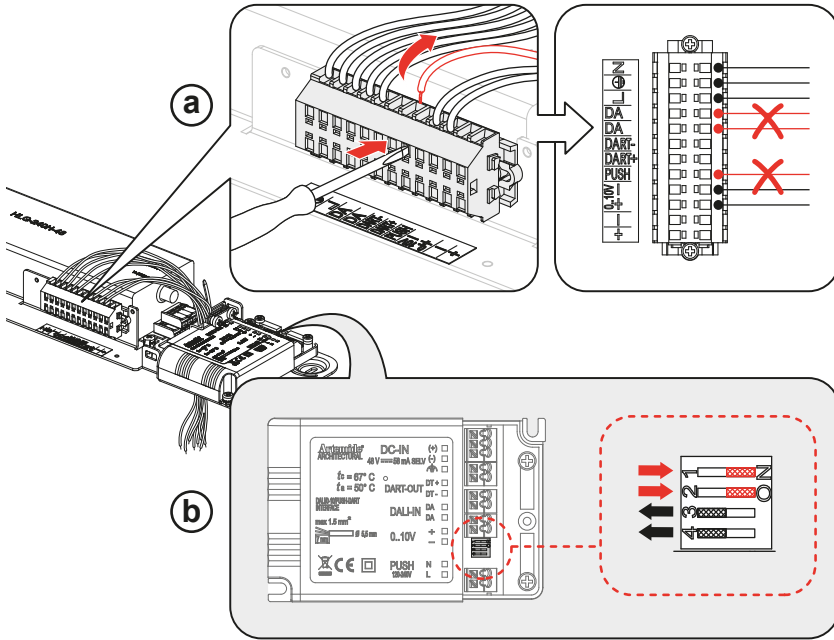



Push

Only for TA610018, TA612228, TA614018, TA616228

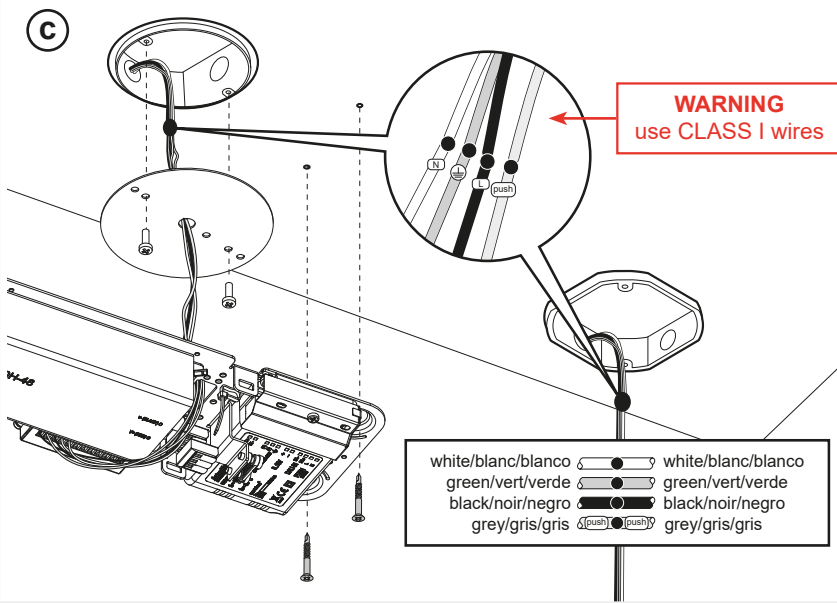
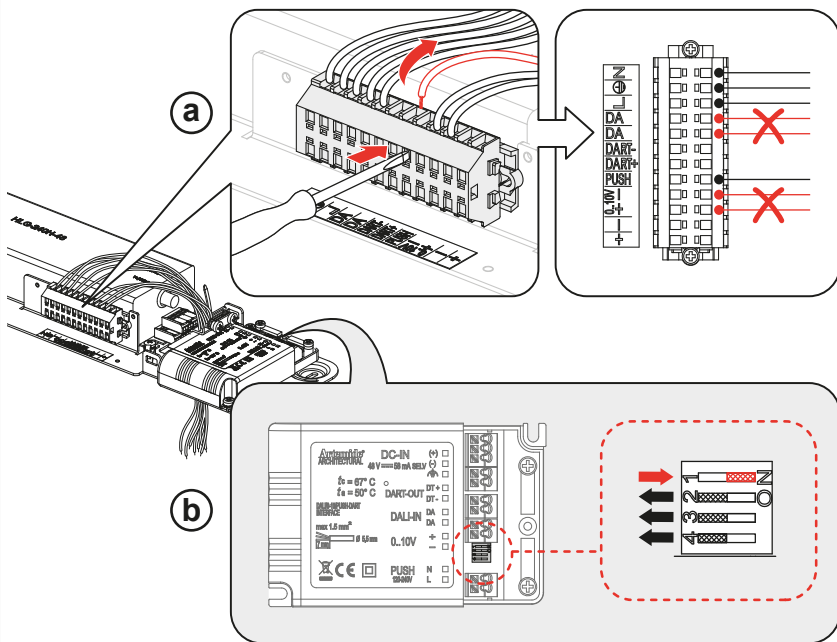



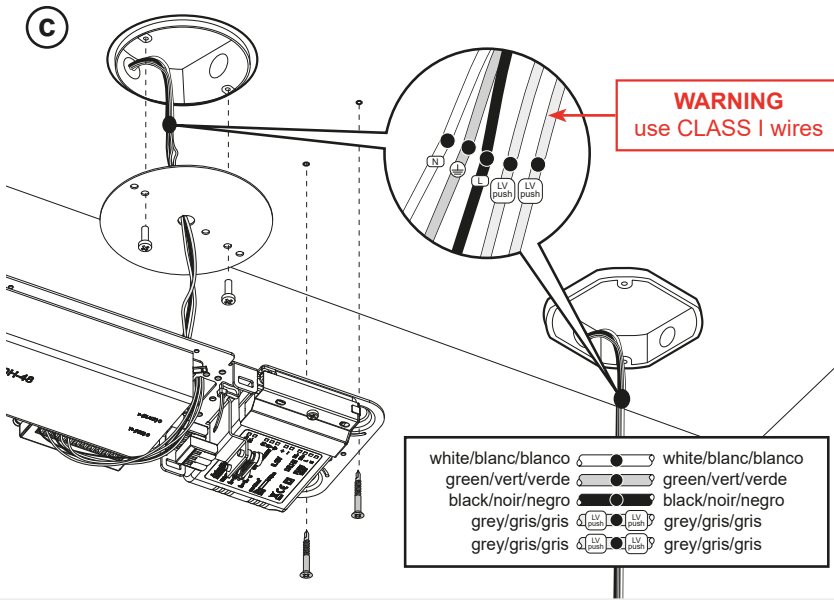
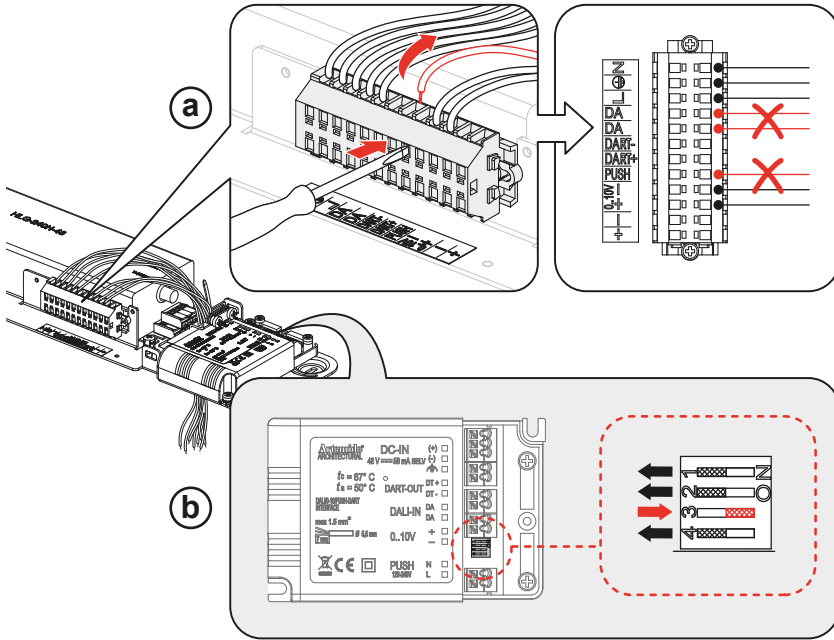

56



Only for TA610018APP, TA612228APP, TA614018APP, TA616228APP

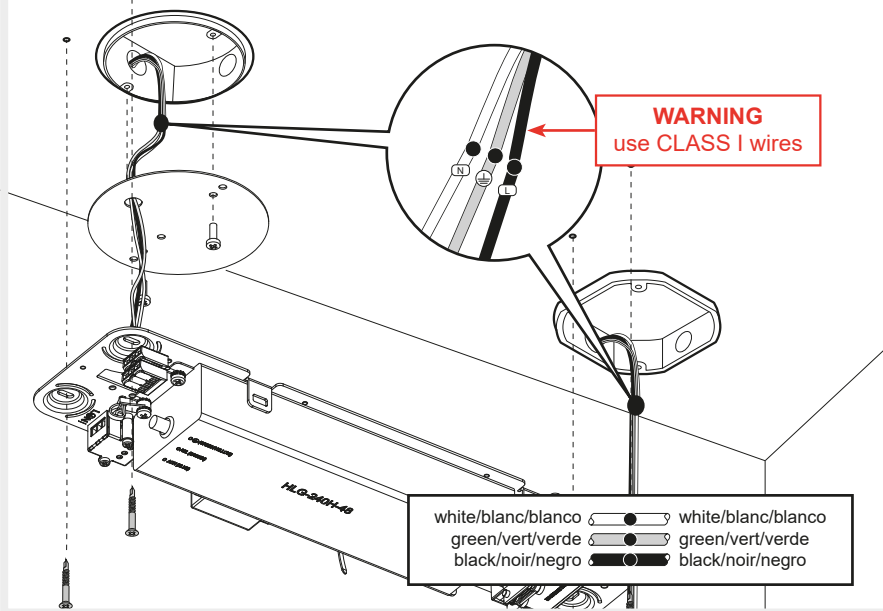

57

Only for TA610018, TA612228, TA614018, TA616228

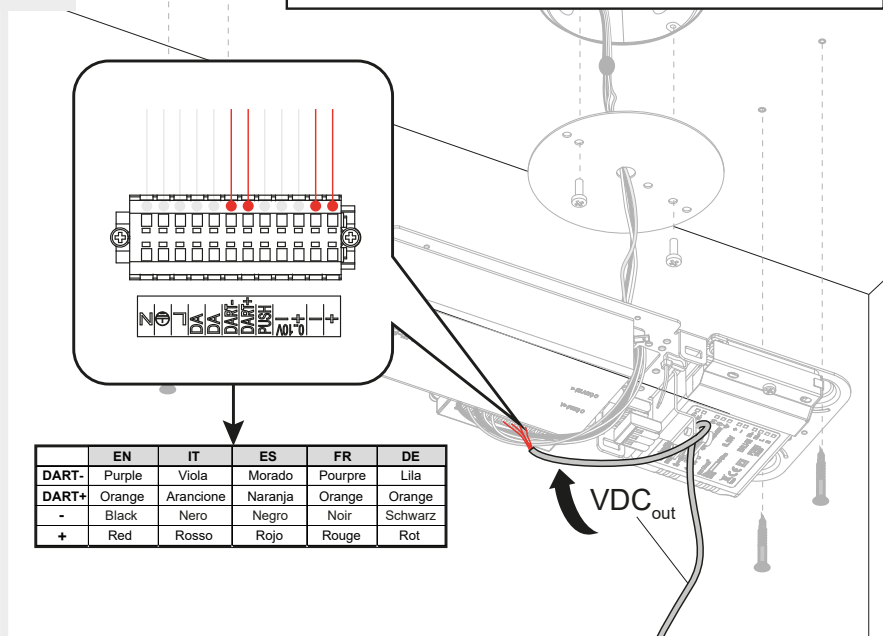

58

Only for TA610018APP, TA612228APP, TA614018APP, TA616228APP

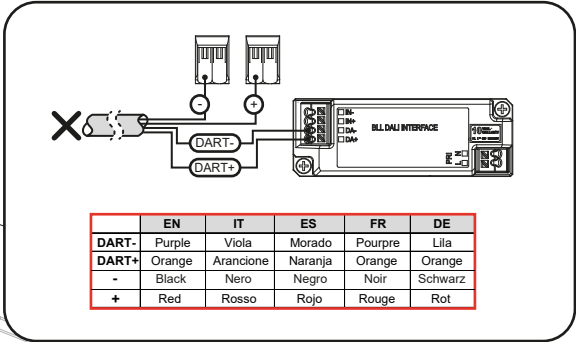

59

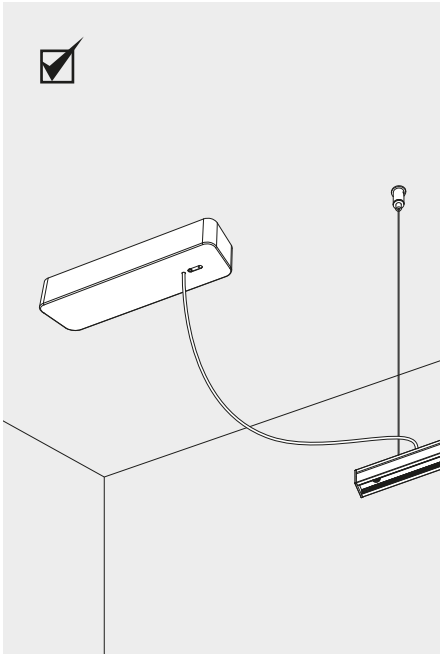
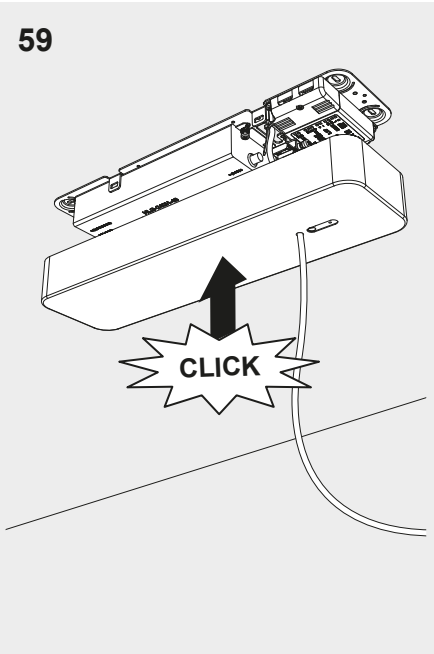

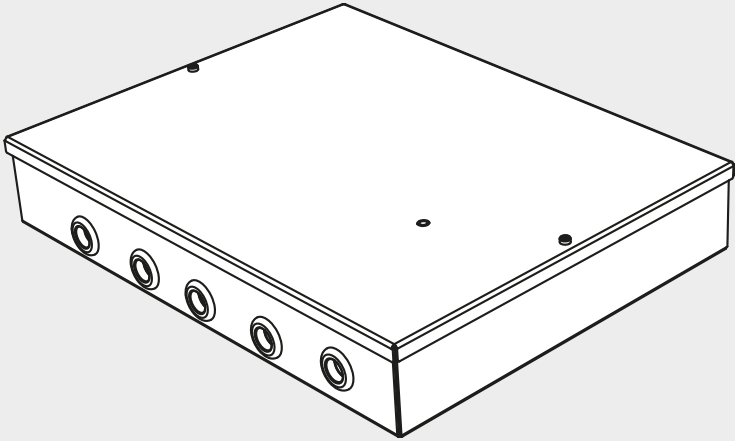

60

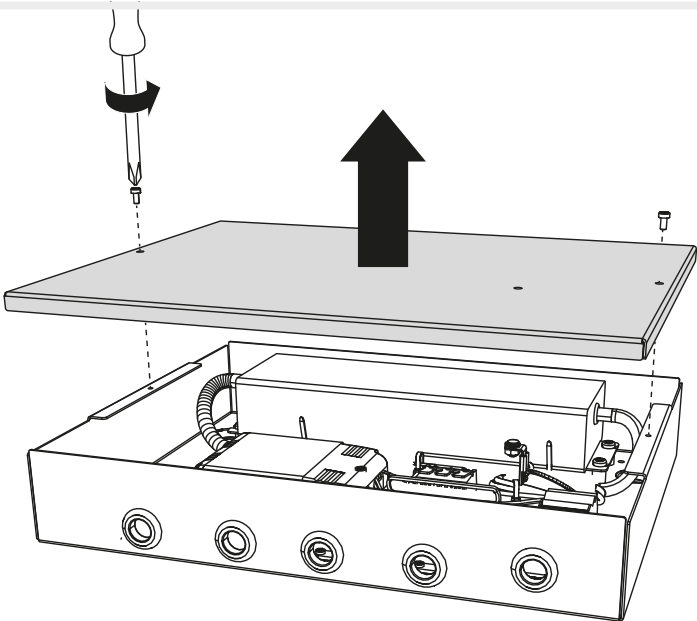

61

**d > 2300 mm - 7.5 ft**

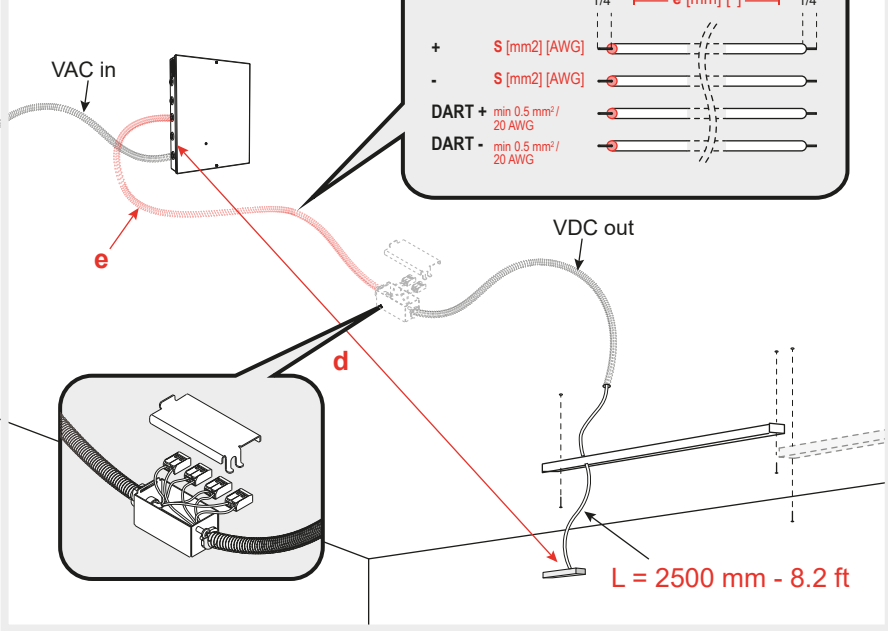

**i**

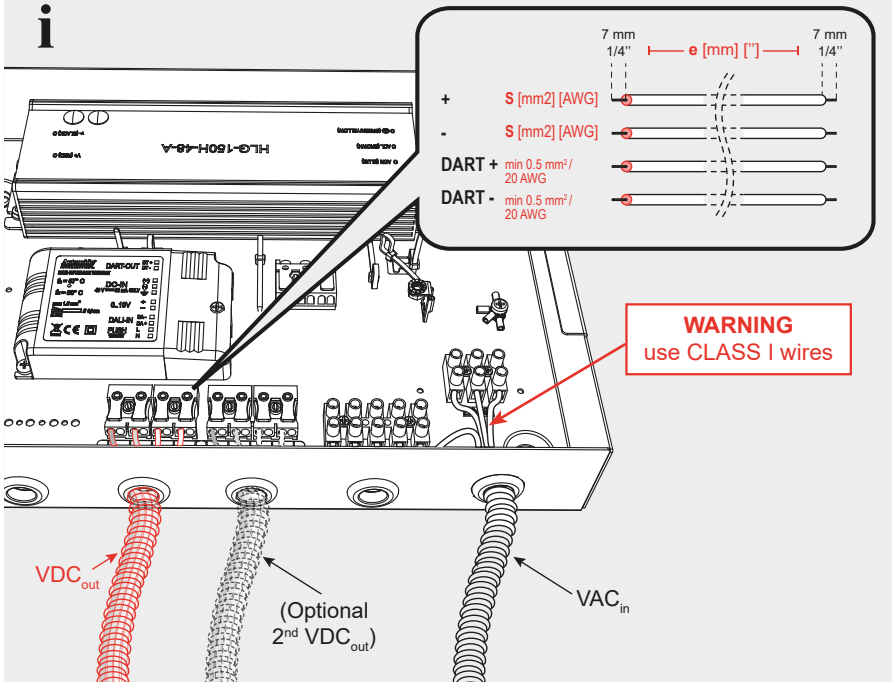

**i****d > 2300 mm - 7.5 ft**

Output max	Extension cord length <b>e</b>		Extension cord cross section <b>S</b>		Max configuration length powerable with a cable length = <b>e + L</b>		
	[W]	[m]	[ft]	[mm <sup>2</sup> ]	[AWG]	[m]	[ft]
125	10	10	32	1	17	58	190
	15	15	49	1.5	16	58	190
210	5	5	16	1	17	35	114
	10	10	32	1.5	16	29	95

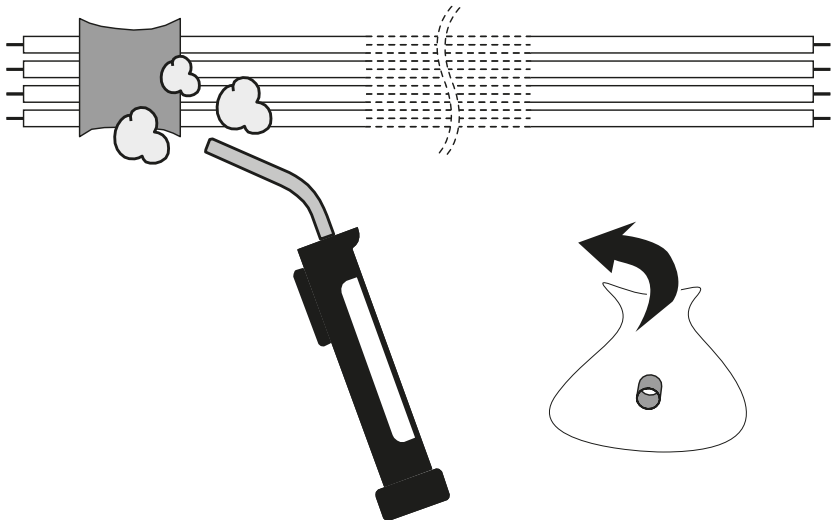
**62**

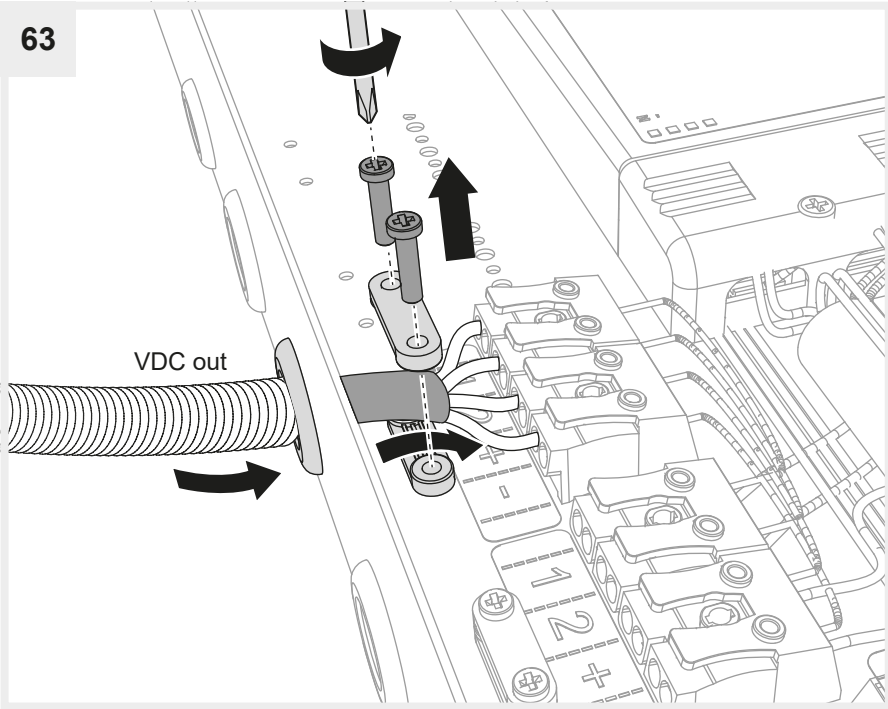
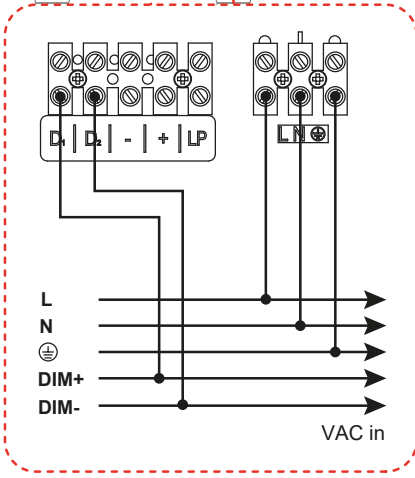
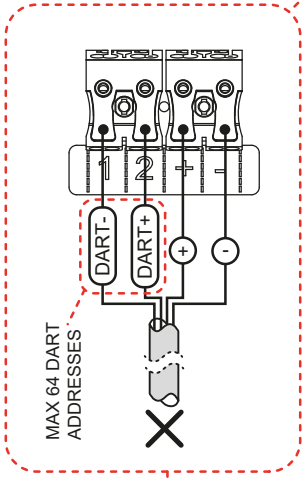
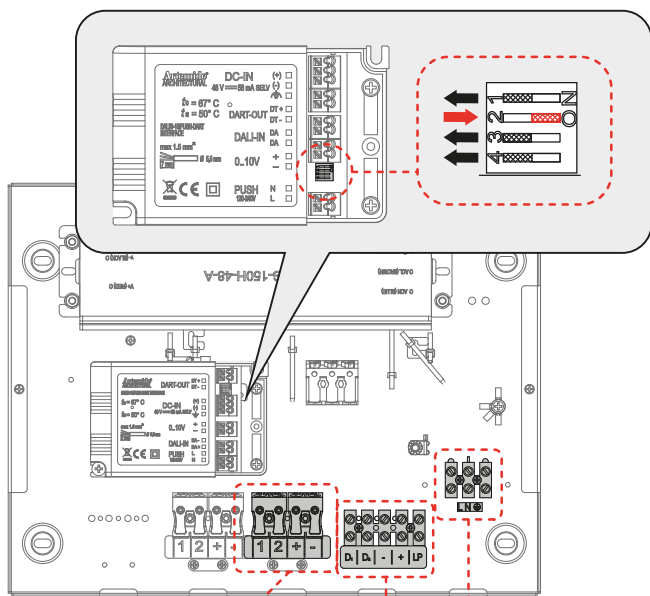

Fig. 64	 DIM 1	0-10V	<b>Only for TA625008</b>
Fig. 65	 DIM 6	Potentiometer	
Fig. 66	 DIM 4	DALI	
Fig. 67	 DIM 2	1-10V	
Fig. 68	 DIM 6	Push	
Fig. 69	 DIM 6	LV Push	
Fig. 70		APP	<b>Only for TA625008APP</b>



	EN	IT	ES	FR	DE
<b>DART-</b>	Purple	Viola	Morado	Pourpre	Lila
<b>DART+</b>	Orange	Aranzone	Naranja	Orange	Orange
<b>-</b>	Black	Nero	Negro	Noir	Schwarz
<b>+</b>	Red	Rosso	Rojo	Rouge	Rot





Only for TA625008

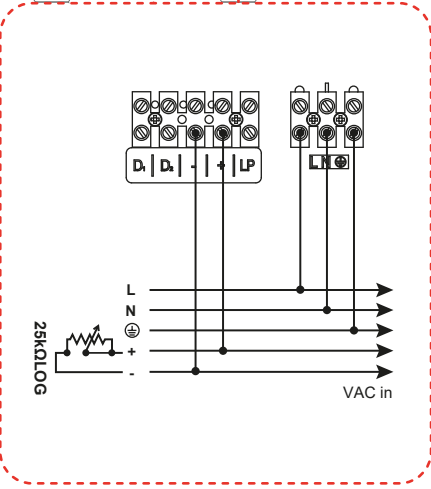
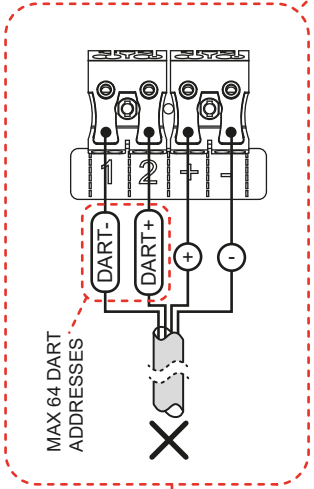
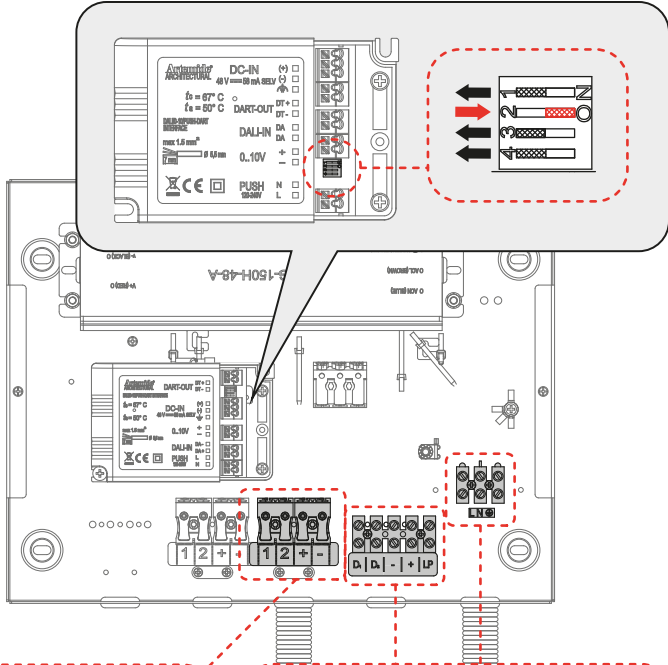

	EN	IT	ES	FR	DE
DART-	Purple	Viola	Morado	Pourpre	Lila
DART+	Orange	Arancione	Naranja	Orange	Orange
-	Black	Nero	Negro	Noir	Schwarz
+	Red	Rosso	Rojo	Rouge	Rot



Only for TA625008

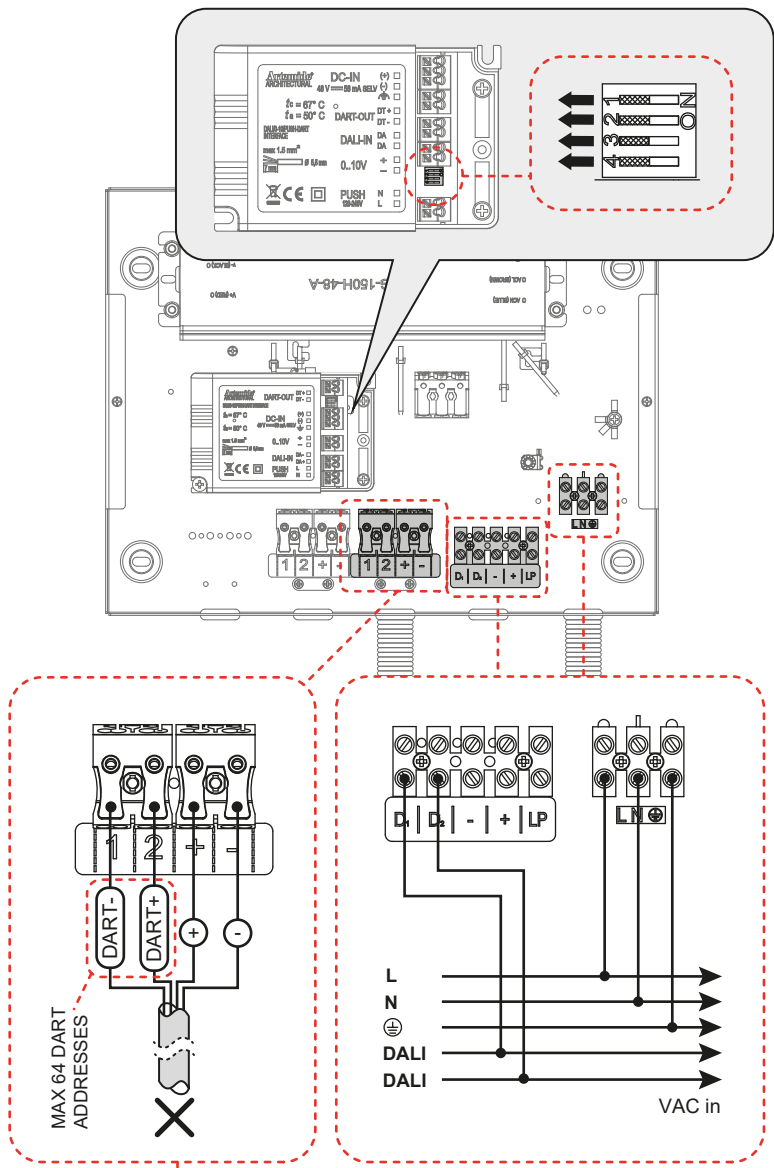

	EN	IT	ES	FR	DE
<b>DART-</b>	Purple	Viola	Morado	Pourpre	Lila
<b>DART+</b>	Orange	Arancione	Naranja	Orange	Orange
<b>-</b>	Black	Nero	Negro	Noir	Schwarz
<b>+</b>	Red	Rosso	Rojo	Rouge	Rot

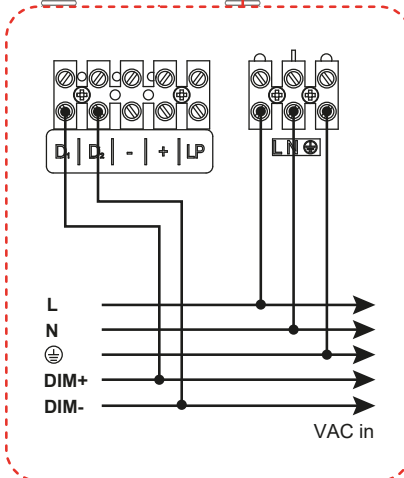
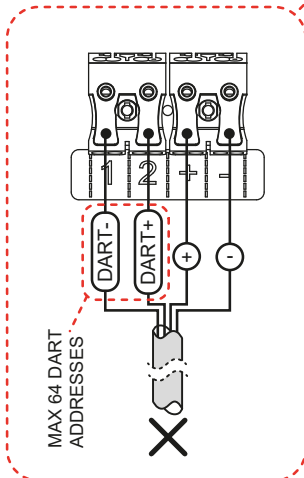
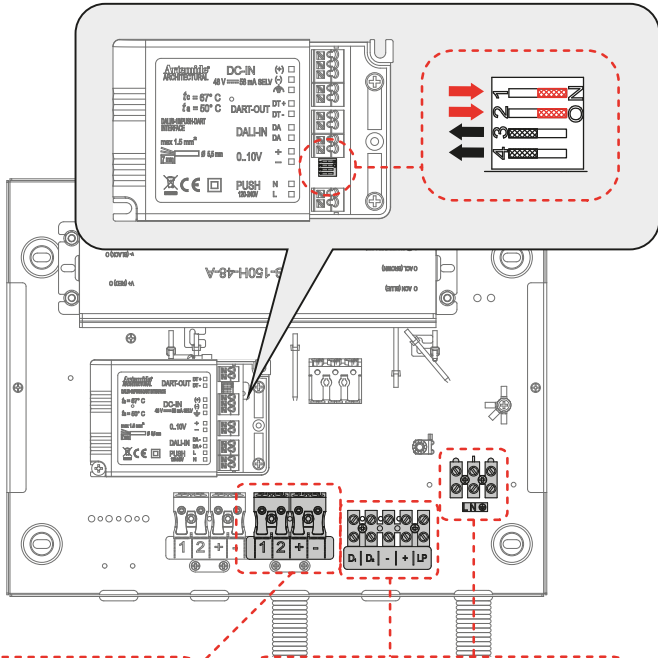

	EN	IT	ES	FR	DE
<b>DART-</b>	Purple	Viola	Morado	Pourpre	Lila
<b>DART+</b>	Orange	Arancione	Naranja	Orange	Orange
<b>-</b>	Black	Nero	Negro	Noir	Schwarz
<b>+</b>	Red	Rosso	Rojo	Rouge	Rot

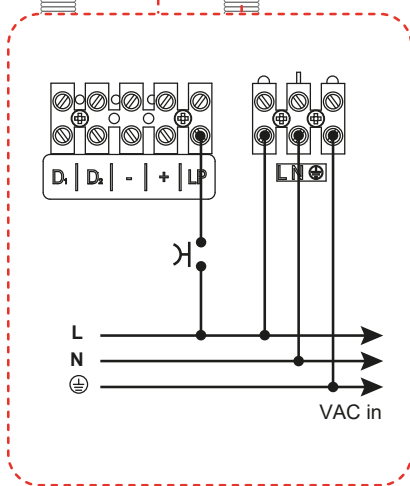
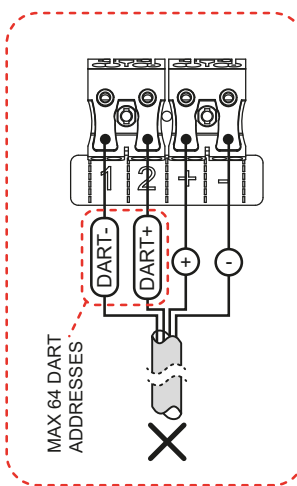
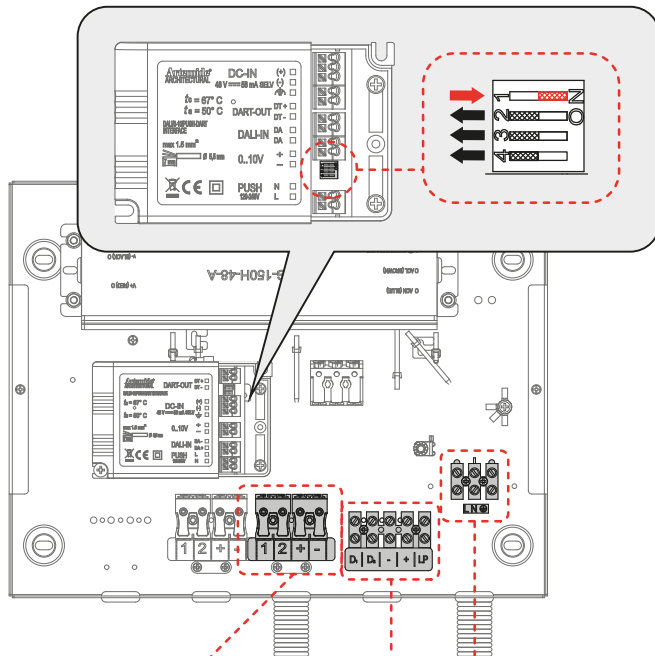

	EN	IT	ES	FR	DE
DART-	Purple	Viola	Morado	Pourpre	Lila
DART+	Orange	Arancione	Naranja	Orange	Orange
-	Black	Nero	Negro	Noir	Schwarz
+	Red	Rosso	Rojo	Rouge	Rot

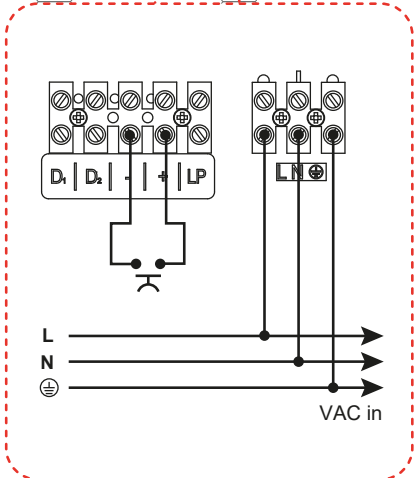
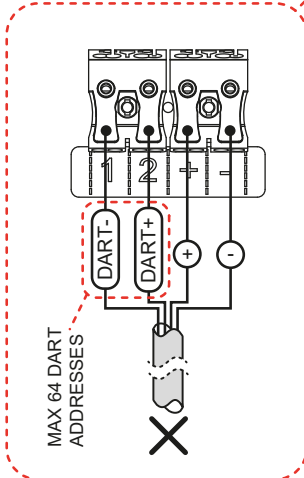
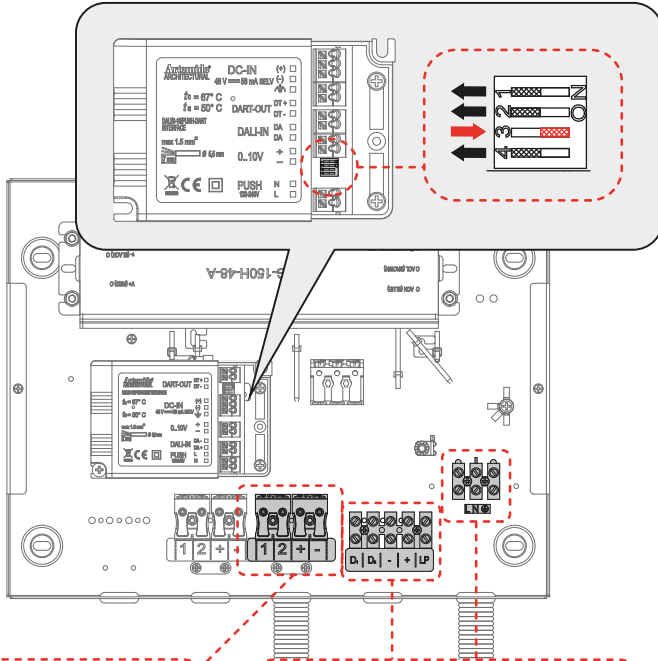

	EN	IT	ES	FR	DE
DART-	Purple	Viola	Morado	Pourpre	Lila
DART+	Orange	Arancione	Naranja	Orange	Orange
-	Black	Nero	Negro	Noir	Schwarz
+	Red	Rosso	Rojo	Rouge	Rot



Only for TA625008APP

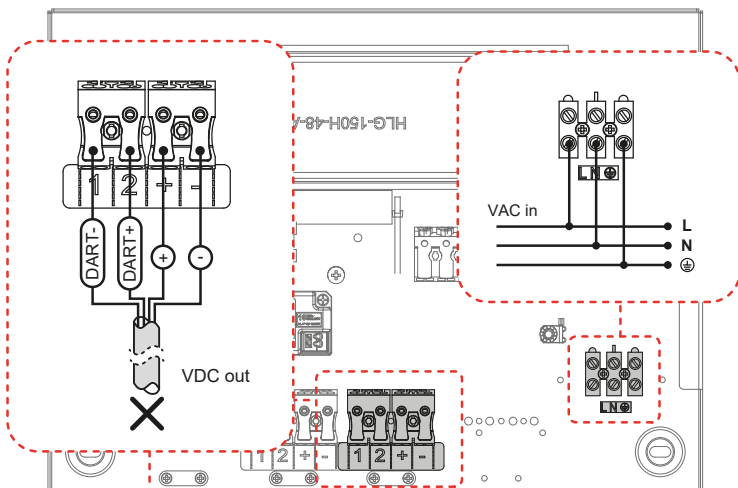

	EN	IT	ES	FR	DE
<b>DART-</b>	Purple	Viola	Morado	Pourpre	Lila
<b>DART+</b>	Orange	Arancione	Naranja	Orange	Orange
<b>-</b>	Black	Nero	Negro	Noir	Schwarz
<b>+</b>	Red	Rosso	Rojo	Rouge	Rot



Only for TA625008APP

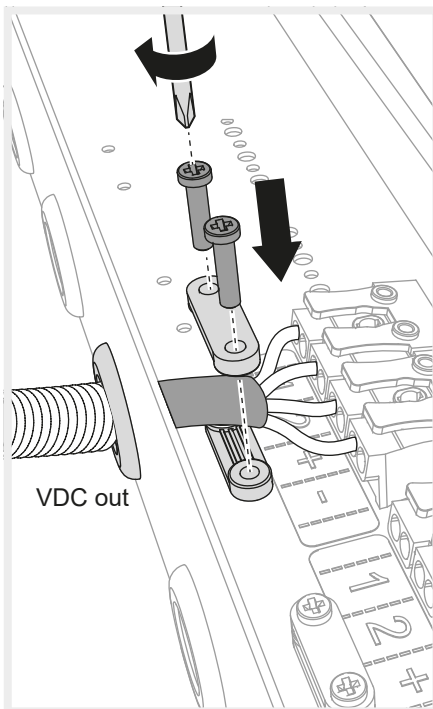
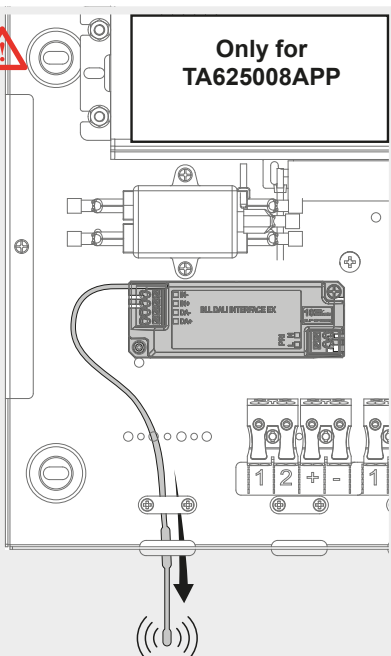

71

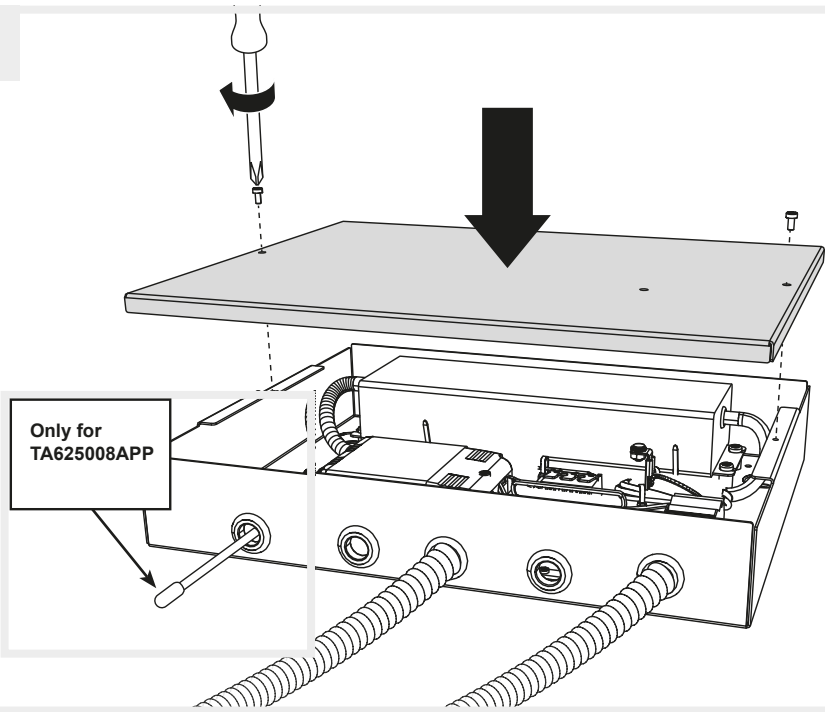

Only for  
TA625008APP

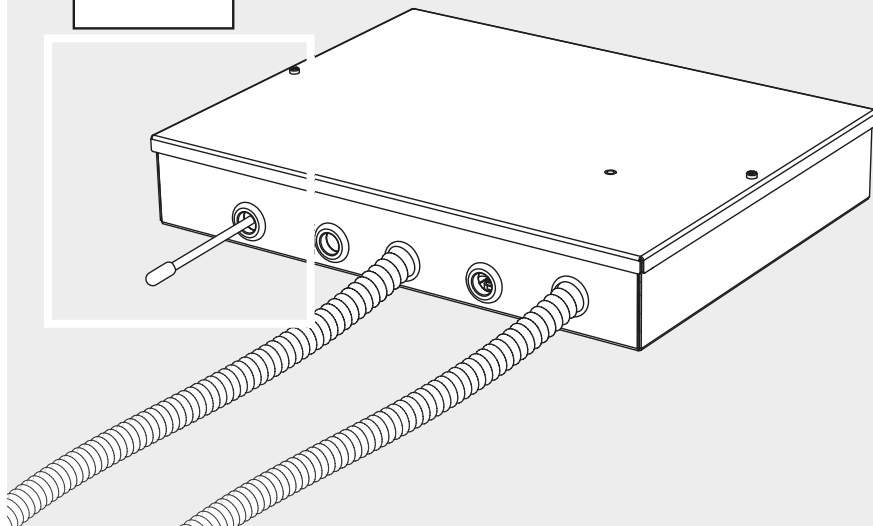

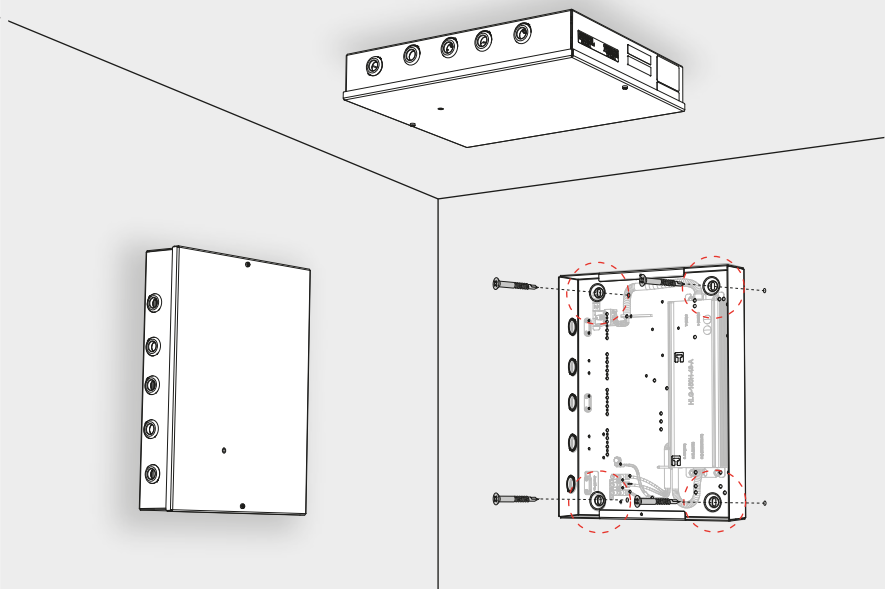

**ONLY FOR TA627008, TA627008APP, TA628008,  
TA628008APP**

Remote Wall/SMD Power Supply Kit must not be installed inside false ceilings, but has to be fixed to the wall or ceiling, outside the wall structure. Electrical wiring does not differ in any way from that shown in section **D3**.

Le kit d'alimentation Remote Wall/SMD ne doit pas être installé à l'intérieur des faux plafonds, mais doit être fixé au mur ou au plafond, à l'extérieur de la structure du mur. Le câblage électrique ne diffère en aucune façon de celui indiqué dans la section **D3**.

El kit de alimentación remota de pared/SMD no debe instalarse dentro de falsos techos, sino que debe fijarse a la pared o al techo, fuera de la estructura de la pared. El cableado eléctrico no difiere en absoluto del mostrado en la sección **D3**.



**i**

Output max	Extension cord length <b>e</b>		Extension cord cross section <b>S</b>		Max configuration length powerable with a cable length = <b>e + L</b>		
	[W]	[m]	[ft]	[mm <sup>2</sup> ]	[AWG]	[m]	[ft]
210		5	16	1	17	35	114
		10	32	1.5	16	29	95
270		5	16	1.5	16	28	91
		10	32	2.5	13	25	82

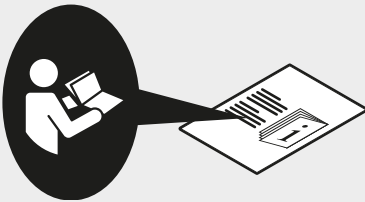





# Artemide®

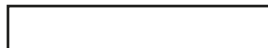

## **Artemide**

via Bergamo, 18  
20010 Pregnana M.se (MI)  
ITALIA

tel. +39 02 935 181  
fax +39 02 935 90 254  
fax +39 02 935 90 496

[www.artemide.com](http://www.artemide.com)

VAT IT00846890150

## **Artemide Inc.**

250 Karin Lane  
Hicksville, NY 11801

tel. 631 694 9292  
Toll Free 1-877-Art-9111  
Fax 631 694 9275

[www.artemide.net](http://www.artemide.net)

## **Artemide Ltée/Ltd.**

11105 rue Renaude Lapointe  
Montréal, Québec H1J 2T4

Tel. 514 323 6537  
Toll Free 888 777 2783  
Fax 514 323 8864

[www.artemide.net](http://www.artemide.net)

cod. Y513001527A