

Project:	Type:
Notes:	

## UNA PRO 150 ADJUSTABLE X1 RECESSED SINGLE (NON-IC)

Design Carlotta de Bevilacqua

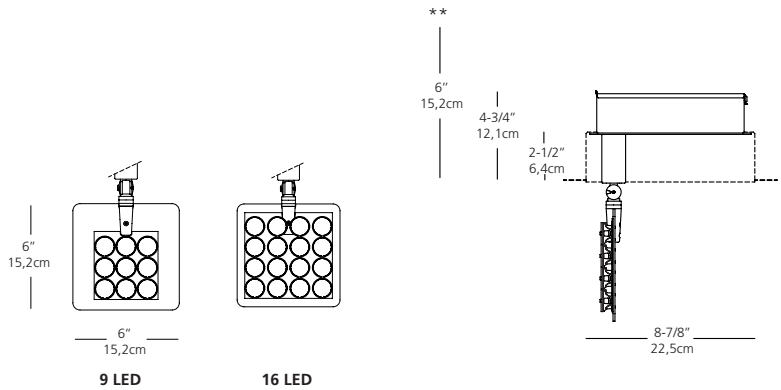

\* Complete installation requires a mounting frame, sold separately (see page 2)

\*\* 6" clearance requires for installation

#CAT	LED	HEAD	CCT	BEAM ANGLE	LENS HOLDER	DRIVER	FINISH
USC-DPU		H1					

QUANTITY

LED	<b>S09</b> = 09 LED <b>S16</b> = 16 LED
HEAD	<b>H1</b> = SINGLE
CCT	<b>30</b> = 3000K, 80CRI
Beam angle	<b>NB</b> = Narrow beam 6° <b>MB</b> = Medium beam 20° <b>WB</b> = Wide beam 38°
Lens holder color	<b>C</b> = Clear
Driver	<b>06</b> = DIM 2 wires (120V only) Phase dimming <b>08</b> = 0-10V dimming (UNV)
Finish	<b>W</b> = White/White (powder coat top plate and heatsink)

For different CCT, CRI or driver options,  
please contact your local Artemide Sales Representative

### TECHNICAL DATA:

	80CRI / 3000k					
	9LED		16LED			
Beam angle:	6°	20°	38°	6°	20°	38°
Power consumption:	11W		21W			
Lumen Nominal:	700lm		1270lm			
Lumen Delivered:	536	529	517	982	929	915
Efficacy lm/W :	48.7	48.1	47	46.8	44.2	43.6
Efficiency (%) :	76%	76%	74%	77%	73%	72%

### PHOTOMETRIC DATA:

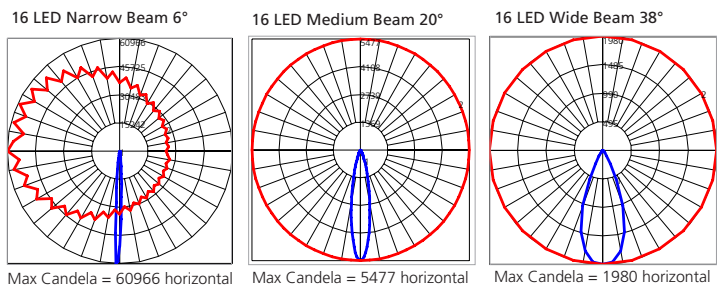
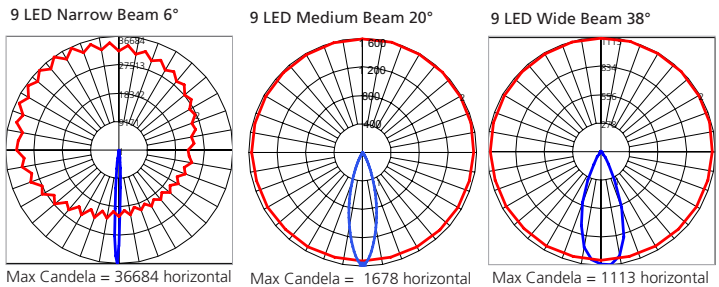

### FEATURES:

- The led board is mounted on a rotating aluminum heatsink allowing a 360° orientation horizontally and 180° vertically.
- Lens holders are available in white and black upon request.
- The galvanized steel driver housing.
- Note: for other finishes, please contact your local Artemide sale representative.

- suitable for dry location

Project:	Type:
Notes:	

**MOUNTING FRAME - UNA PRO 150 ADJUSTABLE X1 RECESSED SINGLE (NON-IC)**  
Design Carlotta de Bevilacqua

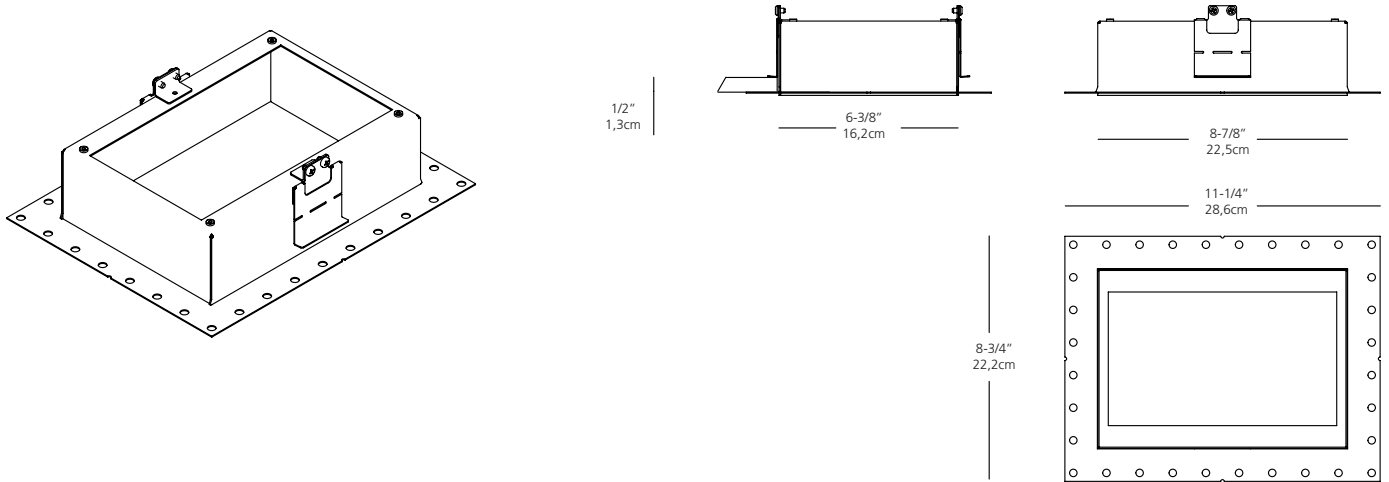

**CEILING CUT-OUT:**

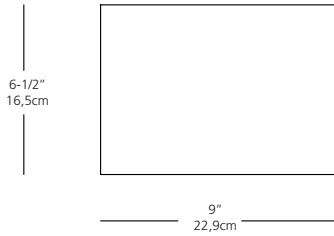

#CAT	FINISH	TEXTURE	QUANTITY
<input type="checkbox"/> USC-DPUSF1W	WHITE	FINE TEXTURE POWDER COAT	

**FEATURES:**

- Cold rolled steel housing with powder coat finish.
- Alignment details available on each sides of the frame for precise alignment.
- Ceiling mounting brackets hold the frame in place without the need of holding it for final adjustment.
- Ceiling brackets can accept ceiling thickness up to 1" (25mm).
- Note: for other finishes, please contact your local Artemide sale representative.

Project:	Type:
Notes:	

UNA PRO ACCESSORIES  
Design Carlotta de Bevilacqua

**Note : Lens kit and Lens Holder Kit are sold separately**



Standard



Optional

**Lens Holder Kit:**

#CAT	type	kit	color	Quantity
USC-DPU	LH	___	___	___

Type	LH = Lens holder
Kit	4 = for 4 LED 16 = for 16 LED
Color	B = Black W = White C = Clear

**Lens Kit:**

#CAT	type	kit	color	Quantity
USC-DPU	L	___	___	___

Type	L = Lens
Kit	4 = for 4 LED 16 = for 16 LED
Color	NB = Narrow Beam 6° MB = Medium Beam 20° WB = Wide Beam 38°